

↔ series

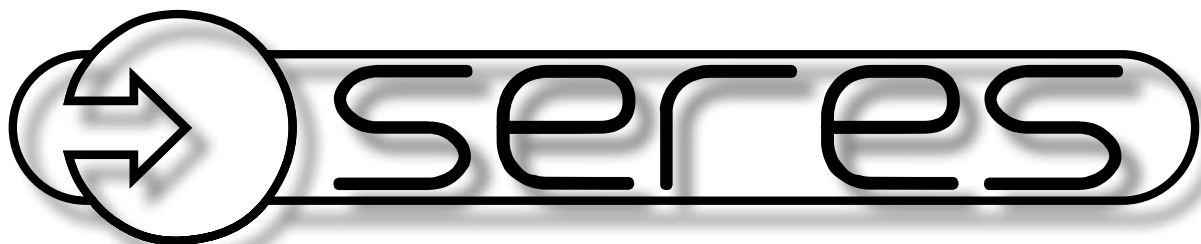

El producto de Muebles Seres, S.A. es testado en laboratorios independientes homologados y cumple la norma*:

EN-12520 // EN-581 // EN-1335
Resistencia, durabilidad y seguridad.

EN-ISO-9227
Resistencia a la corrosión

*Según modelo

Mobiliario uso doméstico

ceramic

	Serie	Estructura	Pag.
J	<i>Jordan Ceramic G0 Cinza</i>	<i>Negro</i>	<i>8</i>
	<i>Jordan Ceramic G0 Roka</i>	<i>Negro</i>	<i>10</i>
	<i>Jordan Ceramic G1,G2,G3</i>	<i>Negro</i>	<i>12</i>
M	<i>M.C. Malta</i>	<i>Negro</i>	<i>17</i>
	<i>M.C. Siri</i>	<i>Negro</i>	<i>16</i>
R	<i>Redox G0 Cinza</i>	<i>Negro</i>	<i>14</i>
	<i>Redox G0 Roka</i>	<i>Negro</i>	<i>15</i>

óxido

	Serie	Estructura	Pag.
O	<i>Syros Óxido</i>	<i>Negro</i>	<i>21</i>
	<i>M.C. Malta y Siri Óxido</i>	<i>Negro</i>	<i>20</i>

cristal blanco

	Serie	Estructura	Pag.
R	<i>Redox cristal blanco 110</i>	<i>Blanco</i>	<i>36</i>
	<i>Redox cristal blanco 100</i>	<i>Blanco</i>	<i>37</i>



top hpl

	Serie	Estructura	Pag.
J	<i>Jordan Top 4 Ibiza</i>	<i>Negro</i>	<i>24</i>
	<i>Jordan Top 5 Tigre</i>	<i>Negro</i>	<i>25</i>
	<i>Jordan Top 6 Pizarra</i>	<i>Negro</i>	<i>26</i>
	<i>Jordan Top 7 Granito</i>	<i>Negro</i>	<i>27</i>
M	<i>M.C. Elev Top</i>	<i>Negro</i>	<i>39</i>
	<i>M.C. Siri Top</i>	<i>Negro</i>	<i>38</i>
R	<i>Redox Top 4 Ibiza</i>	<i>Negro</i>	<i>32</i>
	<i>Redox Top 5 Tigre</i>	<i>Negro</i>	<i>33</i>
	<i>Redox Top 6 Pizarra</i>	<i>Negro</i>	<i>34</i>
	<i>Redox Top 7 Granito</i>	<i>Negro</i>	<i>35</i>
T	<i>Toja Top 1 Blanco</i>	<i>Blanco</i>	<i>28</i>
	<i>Toja Top 2 Marrón</i>	<i>Marrón</i>	<i>30</i>
	<i>Toja Top 3 Gris</i>	<i>Gris</i>	<i>31</i>



melamina

	Serie	Estructura	Pag.
F	<i>Forest Boreal Canto Madera</i>	<i>Negro</i>	<i>49</i>
	<i>Forest Boreal Canto Negro</i>	<i>Negro</i>	<i>48</i>
	<i>Forest Nature Canto Madera</i>	<i>Negro</i>	<i>45</i>
	<i>Forest Nature Canto Negro</i>	<i>Negro</i>	<i>44</i>
	<i>Forest Niagara Canto Madera</i>	<i>Negro</i>	<i>43</i>
	<i>Forest Niagara Canto Negro</i>	<i>Negro</i>	<i>42</i>
	<i>Forest Tabak Canto Madera</i>	<i>Negro</i>	<i>47</i>
	<i>Forest Tabak Canto Negro</i>	<i>Negro</i>	<i>46</i>







CERAMIC: PORCELÁNICO + CRISTAL

La gama CERAMIC de Seres presenta las encimeras porcelánicas más resistentes y atractivas. Sólidas y duraderas, mantienen su belleza y personalidad inalterables frente al paso de los años. CERAMIC es un material versátil que ofrece una

amplia variedad de soluciones.

Las encimeras CERAMIC son resistentes a todo tipo de manchas: vino, aceite... Basta con un paño húmedo para recuperar su aspecto original

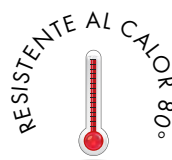

GRUPO
muebles
INTERMOBEL



ADVERTENCIA: Se recomienda NO aplicar sobre la superficie CERAMIC ollas, sartenes o cualquier objeto que haya estado en contacto con el fuego o a altas temperaturas.

Jordan CERAMIC GO CINZA







CINZA

muebles
GRUPO INTERMOBEL







jordan CERAMIC **G0 cinza**

estructura	pata	color	cód.
NEGRO  140 cm. • 210 cm.	X 	negro	941.745
		blanco	941.645
		pedra	941.845
		gris	941.945
	V 	negro	942.745
		blanco	942.645
		pedra	942.845
		gris	942.945
	O 	negro	943.745
		A 	negro





140
X
90

jordan CERAMIC **G0 cinza**

estructura	pata	color	cód.
NEGRO  160 cm. • 240 cm.	X 	negro	961.745
		blanco	961.645
		pedra	961.845
		gris	961.945
	V 	negro	962.745
		blanco	962.645
		pedra	962.845
		gris	962.945
	O 	negro	963.745
		A 	negro

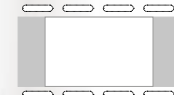
160
X
90

jordan CERAMIC **G0 cinza**

estructura	pata	color	cód.
NEGRO  180 cm. • 260 cm.	X 	negro	981.745
		blanco	981.645
		pedra	981.845
		gris	981.945
	V 	negro	982.745
		blanco	982.645
		pedra	982.845
		gris	982.945
	O 	negro	983.745
		A 	negro

180
X
100



Jordan pata X
CERAMIC G0 Cinza

Jordan CERAMIC GO ROKA





ROKA

muebles
INTERMOBEL



Jordan pata A
CERAMIC G0 Roka

jordan CERAMIC G0 roka

estructura	pata	color	cód.
NEGRO 140 cm. • 210 cm.		negro	941.744
		blanco	941.644
		pedra	941.844
		gris	941.944
140 X 90		negro	942.744
		blanco	942.644
		pedra	942.844
		gris	942.944
		negro	943.744
		negro	944.744

jordan CERAMIC G0 roka

estructura	pata	color	cód.
NEGRO 160 cm. • 240 cm.		negro	961.744
		blanco	961.644
		pedra	961.844
		gris	961.944
160 X 90		negro	962.744
		blanco	962.644
		pedra	962.844
		gris	962.944
		negro	963.744
		negro	964.744

jordan CERAMIC G0 roka

estructura	pata	color	cód.
NEGRO 180 cm. • 260 cm.		negro	981.744
		blanco	981.644
		pedra	981.844
		gris	981.944
180 X 100		negro	982.744
		blanco	982.644
		pedra	982.844
		gris	982.944
		negro	983.744
		negro	984.744

Jordan GAMA CERAMIC

G1



G1 Basic black

Techlam



G1 Basic neu

Techlam



G1 Blaze dark

Techlam



G1 Blaze grey

Techlam



G1 Blaze snow

Techlam



G1 Hydra argen

Techlam



G1 Hydra plomo

Techlam



G1 Vulcano ceniza

Techlam

G2



G2 Steel corten

Techlam



G2 Steel dark

Techlam



G2 Steel white

Techlam

G3

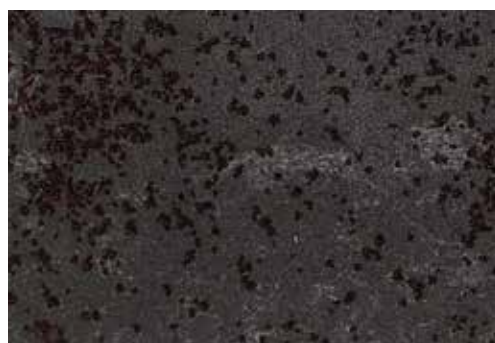

G3 Iron grey

Neolith



G3 Kalos blanco





Techlam







G3 Noir desir

Laminam



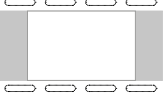

G1 jordan CERAMIC

estructura	pata	color	cód.
NEGRO  140 cm. • 210 cm.		negro	941.741
		blanco	941.641
		piedra	941.841
		gris	941.941
140 X 90		negro	942.741
		blanco	942.641
		piedra	942.841
		gris	942.941
	negro	943.741	
		negro	944.741



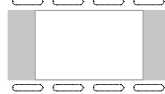

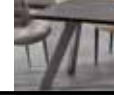
G1 jordan CERAMIC

estructura	pata	color	cód.
NEGRO  160 cm. • 240 cm.		negro	961.741
		blanco	961.641
		piedra	961.841
		gris	961.941
160 X 90		negro	962.741
		blanco	962.641
		piedra	962.841
		gris	962.941
	negro	963.741	
		negro	964.741



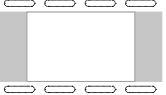

G1 jordan CERAMIC

estructura	pata	color	cód.
NEGRO  180 cm. • 260 cm.		negro	981.741
		blanco	981.641
		piedra	981.841
		gris	981.941
180 X 100		negro	982.741
		blanco	982.641
		piedra	982.841
		gris	982.941
	negro	983.741	
		negro	984.741



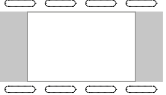

G2 jordan CERAMIC

estructura	pata	color	cód.
NEGRO  140 cm. • 210 cm.		negro	941.742
		blanco	941.642
		piedra	941.842
		gris	941.942
140 X 90		negro	942.742
		blanco	942.642
		piedra	942.842
		gris	942.942
	negro	943.742	
		negro	944.742



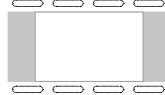

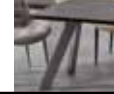
G2 jordan CERAMIC

estructura	pata	color	cód.
NEGRO  160 cm. • 240 cm.		negro	961.742
		blanco	961.642
		piedra	961.842
		gris	961.942
160 X 90		negro	962.742
		blanco	962.642
		piedra	962.842
		gris	962.942
	negro	963.742	
		negro	964.742



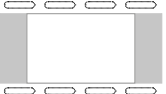

G2 jordan CERAMIC

estructura	pata	color	cód.
NEGRO  180 cm. • 260 cm.		negro	981.742
		blanco	981.642
		piedra	981.842
		gris	981.942
180 X 100		negro	982.742
		blanco	982.642
		piedra	982.842
		gris	982.942
	negro	983.742	
		negro	984.742





G3 jordan CERAMIC

estructura	pata	color	cód.
NEGRO  140 cm. • 210 cm.		negro	941.743
		blanco	941.643
		piedra	941.843
		gris	941.943
140 X 90		negro	942.743
		blanco	942.643
		piedra	942.843
		gris	942.943
	negro	943.743	
		negro	944.743

G3 jordan CERAMIC

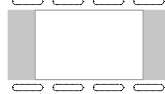
estructura	pata	color	cód.
NEGRO  160 cm. • 240 cm.		negro	961.743
		blanco	961.643
		piedra	961.843
		gris	961.943
160 X 90		negro	962.743
		blanco	962.643
		piedra	962.843
		gris	962.943
	negro	963.743	
		negro	964.743

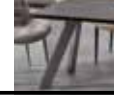
G3 jordan CERAMIC

estructura	pata	color	cód.
NEGRO  180 cm. • 260 cm.		negro	981.743
		blanco	981.643
		piedra	981.843
		gris	981.943
180 X 100		negro	982.743
		blanco	982.643
		piedra	982.843
		gris	982.943
	negro	983.743	
		negro	984.743

Redox CERAMIC GO CINZA



Redox
G0 Cinza

redox G0 Cinza 110x95

ref.	patas	estructura	sobre
600.206	negro	negro	cinza
600.211	blanco	negro	cinza

MESA OVALADA EXTENSIBLE - 2 ALAS 110 (2x30) x 95

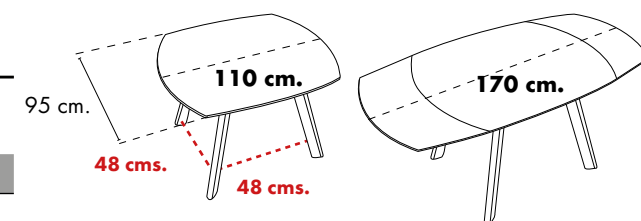

Redox CERAMIC GO ROKA



CERAMIC



sistema apertura *fácil* mesa Redox



www.mesaredox.com

redox **G0 Roka**

110x95

ref.	patas	estructura	sobre
600.205	negro	negro	roka
600.210	blanco	negro	roka

MESA OVALADA EXTENSIBLE - 2 ALAS 110 (2x30) x 95

GRUPO **INTERMOBEL**

M.C. Siri CERAMIC



GRUPO **INTERMOBEL**

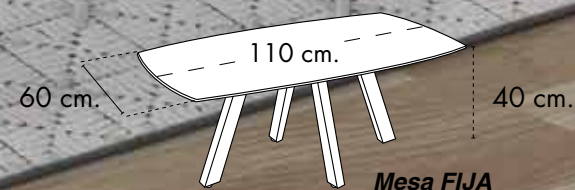

siri CERAMIC pata negro

ref.	patas	sobre
861.744	negro	G0 roka
861.745	negro	G0 cinza
861.741	negro	G1
861.742	negro	G2
861.743	negro	G3

siri CERAMIC pata blanco

ref.	patas	sobre
861.644	blanco	G0 roka
861.645	blanco	G0 cinza
861.641	blanco	G1
861.642	blanco	G2
861.643	blanco	G3

siri CERAMIC pata piedra

ref.	patas	sobre
861.844	piedra	G0 roka
861.845	piedra	G0 cinza
861.841	piedra	G1
861.842	piedra	G2
861.843	piedra	G3

siri CERAMIC pata gris

ref.	patas	sobre
861.944	gris	G0 roka
861.945	gris	G0 cinza
861.941	gris	G1
861.942	gris	G2
861.943	gris	G3

M.C. Malta CERAMIC

GRUPO MUEBLES INTERMOBEL



m.c. Malta CERAMIC pata negro

ref.	patas	sobre
841.744	negro	G0 roka
841.745	negro	G0 cinza
841.741	negro	G1
841.742	negro	G2
841.743	negro	G3

m.c. Malta CERAMIC pata blanco

ref.	patas	sobre
841.644	blanco	G0 roka
841.645	blanco	G0 cinza
841.641	blanco	G1
841.642	blanco	G2
841.643	blanco	G3

m.c. Malta CERAMIC pata piedra

ref.	patas	sobre
841.844	piedra	G0 roka
841.845	piedra	G0 cinza
841.841	piedra	G1
841.842	piedra	G2
841.843	piedra	G3

m.c. Malta CERAMIC pata gris

ref.	patas	sobre
841.944	gris	G0 roka
841.945	gris	G0 cinza
841.941	gris	G1
841.942	gris	G2
841.943	gris	G3





ÓXIDO: PINTURA CERÁMICA + CRISTAL TEMPLADO

Es el proceso de pintado del vidrio. La pintura se aplica con pantalla o rodillo y se funde a 700° C con la masa vítrea. El color permanece inalterable. El vitrificado confiere una adhesión permanente del vidrio y la pintura.

Para este proceso se utilizan exclusivamente pinturas cerámicas de alta resistencia. El resultado son superficies de vidrios decorados, resistentes a abrasiones, choques térmicos y las incidencias de rayos UVA.



GRUPO **INTERMOBEL**

ADVERTENCIA: Se recomienda NO aplicar sobre la superficie OXIDO ollas, sartenes o cualquier objeto que haya estado en contacto con el fuego o a altas temperaturas.

Syros ÓXIDO

GRUPO MUEBLES
INTERMOBEL



Syros pata A
ÓXIDO

M.C. siri *Óxido Fija* Mesa centro

ref.	pata	estructura	sobre
861.731	negro	negro	óxido
861.631	blanco	negro	óxido
861.831	pedra	negro	óxido
861.931	gris	negro	óxido

M.C. malta *Óxido Elevable* Mesa centro

ref.	pata	estructura	sobre
841.731	negro	negro	óxido
841.631	blanco	negro	óxido
841.831	pedra	negro	óxido
841.931	gris	negro	óxido

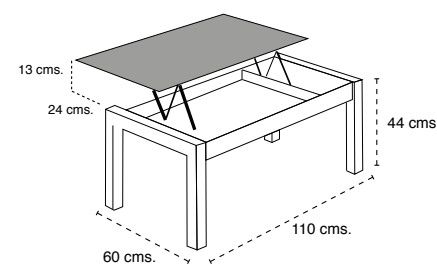
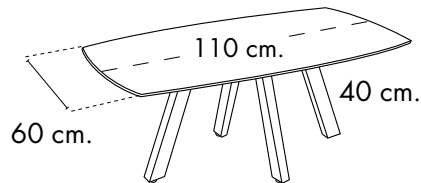

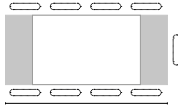

syros *Óxido*

estructura	pata	color	cód.	
 <p>140 cm. • 210 cm.</p> <p>140 X 90</p>	X	negro	600.906	
		blanco	600.905	
		pedra	600.907	
		gris	600.908	
	V	negro	600.901	
		blanco	600.900	
		pedra	600.902	
		gris	600.903	
		O	negro	600.910
		A	negro	600.915

syros *Óxido*

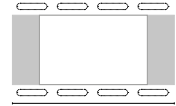
estructura	pata	color	cód.	
 <p>160 cm. • 240 cm.</p> <p>160 X 90</p>	X	negro	600.926	
		blanco	600.925	
		pedra	600.927	
		gris	600.928	
	V	negro	600.921	
		blanco	600.920	
		pedra	600.922	
		gris	600.923	
		O	negro	600.930
		A	negro	600.935

syros *Óxido*

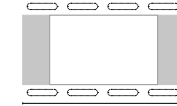
estructura	pata	color	cód.	
 <p>180 cm. • 260 cm.</p> <p>180 X 100</p>	X	negro	600.946	
		blanco	600.945	
		pedra	600.947	
		gris	600.948	
	V	negro	600.941	
		blanco	600.940	
		pedra	600.942	
		gris	600.943	
		O	negro	600.950
		A	negro	600.955



GRUPO **INTERMOBEL**
muebles



TOP HPL: CRISTAL TEMPLADO + LAMINADO FORMICA®

El tablero TOP HPL (*High Pressure Laminate*) es un material compuesto de varias capas de celulosa impregnadas en resinas fenólicas, las cuales son sometidas a procesos de grandes tensiones y altas temperaturas que aportan al producto muchas ven-

tajas.

- Innovación en diseño de la últimas tendencias.
- Resistencia al desgaste, al agua, productos químicos y abrasiones.
- Facilidad de limpieza, mantenimiento y alta durabilidad

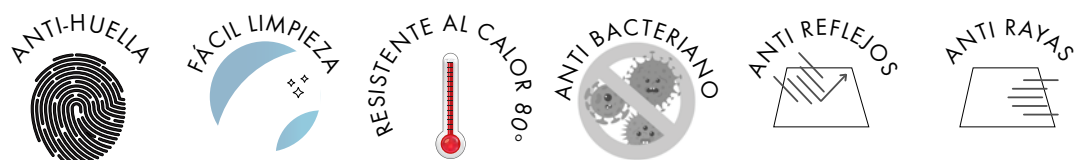

GRUPO MUEBLES
INTERMOBEL



ADVERTENCIA: Se recomienda NO aplicar sobre la superficie TOP HPL ollas, sartenes o cualquier objeto que haya estado en contacto con el fuego o a altas temperaturas.

Jordan TOP 4 IBIZA



Jordan pata V
TOP 4 Ibiza

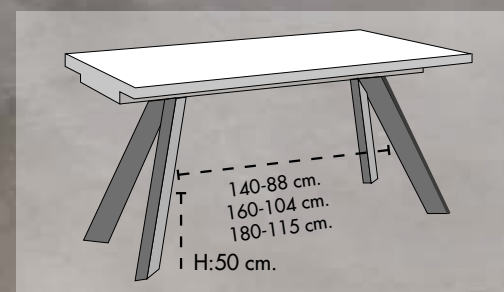

jordan TOP 4 // Ibiza

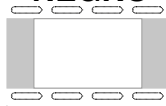
estructura	pata	color	cód.
NEGRO  140 cm. • 210 cm.	X	negro	941.724
		blanco	941.624
		piedra	941.824
		gris	941.924
	V	negro	942.724
		blanco	942.624
		piedra	942.824
		gris	942.924
	O	negro	943.724
		negro	944.724
	A	negro	944.724

140
X
90

jordan TOP 4 // Ibiza

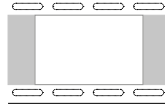
estructura	pata	color	cód.
NEGRO  160 cm. • 240 cm.	X	negro	961.724
		blanco	961.624
		piedra	961.824
		gris	961.924
	V	negro	962.724
		blanco	962.624
		piedra	962.824
		gris	962.924
	O	negro	963.724
		negro	964.724
	A	negro	964.724

160
X
90

jordan TOP 4 // Ibiza

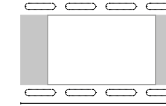
estructura	pata	color	cód.
NEGRO  180 cm. • 260 cm.	X	negro	981.724
		blanco	981.624
		piedra	981.824
		gris	981.924
	V	negro	982.724
		blanco	982.624
		piedra	982.824
		gris	982.924
	O	negro	983.724
		negro	984.724
	A	negro	984.724

180
X
100



Jordan TOP5 TIGRE

TOP HPL



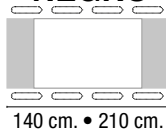

Jordan pata X
TOP 5 Tigre

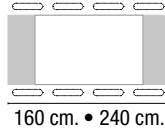

jordan TOP 5 / Tigre

estructura	pata	color	cód.	
 140 cm. • 210 cm.	X	negro	941.725	
		blanco	941.625	
		piedra	941.825	
		gris	941.925	
		V	negro	942.725
	 140 X 90	blanco	942.625	
		piedra	942.825	
		gris	942.925	
		O	negro	943.725
	 140 X 90	A	negro	944.725

jordan TOP 5 / Tigre

estructura	pata	color	cód.	
 160 cm. • 240 cm.	X	negro	961.725	
		blanco	961.625	
		piedra	961.825	
		gris	961.925	
		V	negro	962.725
	 160 X 90	blanco	962.625	
		piedra	962.825	
		gris	962.925	
		O	negro	963.725
	 160 X 90	A	negro	964.725

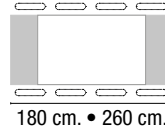
jordan TOP 5 / Tigre





estructura	pata	color	cód.	
 180 cm. • 260 cm.	X	negro	981.725	
		blanco	981.625	
		piedra	981.825	
		gris	981.925	
		V	negro	982.725
	 180 X 100	blanco	982.625	
		piedra	982.825	
		gris	982.925	
		O	negro	983.725
	 180 X 100	A	negro	984.725

Jordan TOP 6 PIZARRA



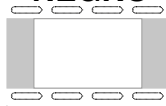



Jordan pata A
TOP 6 Pizarra



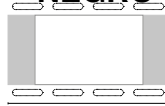

jordan TOP 6 /Pizarra

estructura	pata	color	cód.
 140 cm. • 210 cm. 140 X 90	NEGRO	X	negro 941.726
			blanco 941.626
			pedra 941.826
			gris 941.926
	V	negro 942.726	
		blanco 942.626	
		pedra 942.826	
		gris 942.926	
	O	negro 943.726	
		A	negro 944.726
			

jordan TOP 6 /Pizarra

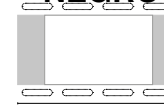
estructura	pata	color	cód.
 160 cm. • 240 cm. 160 X 90	NEGRO	X	negro 961.726
			blanco 961.626
			pedra 961.826
			gris 961.926
	V	negro 962.726	
		blanco 962.626	
		pedra 962.826	
		gris 962.926	
	O	negro 963.726	
		A	negro 964.726
			

jordan TOP 6 /Pizarra

estructura	pata	color	cód.
 180 cm. • 260 cm. 180 X 100	NEGRO	X	negro 981.726
			blanco 981.626
			pedra 981.826
			gris 981.926
	V	negro 982.726	
		blanco 982.626	
		pedra 982.826	
		gris 982.926	
	O	negro 983.726	
		A	negro 984.726
			

Jordan TOP7 GRANITO

TOP HPL



Jordan pata O
TOP 7 Granito

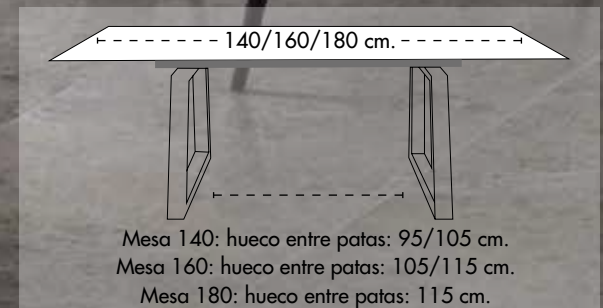

jordan TOP 7/Granito

estructura	pata	color	cód.	
<p>140 cm. • 210 cm.</p>	X	negro	941.727	
		blanco	941.627	
		pedra	941.827	
		gris	941.927	
	140 X 90	V	negro	942.727
			blanco	942.627
			pedra	942.827
			gris	942.927
	O	negro	943.727	
		A	negro	944.727

jordan TOP 7/Granito

estructura	pata	color	cód.	
<p>160 cm. • 240 cm.</p>	X	negro	961.727	
		blanco	961.627	
		pedra	961.827	
		gris	961.927	
	160 X 90	V	negro	962.727
			blanco	962.627
			pedra	962.827
			gris	962.927
	O	negro	963.727	
		A	negro	964.727

jordan TOP7/Granito

estructura	pata	color	cód.	
<p>180 cm. • 260 cm.</p>	X	negro	981.727	
		blanco	981.627	
		pedra	981.827	
		gris	981.927	
	180 X 100	V	negro	982.727
			blanco	982.627
			pedra	982.827
			gris	982.927
	O	negro	983.727	
		A	negro	984.727

Toja TOP1 BLANCO





Toja pata X
TOP 1 blanco

toja TOP 1/ *Blanco*

estructura	pata	color	cód.
BLANCO 140 cm. • 210 cm.		negro	600.377
		blanco	600.375
		pedra	600.378
		gris	600.379
140 X 90		negro	600.402
		blanco	600.401
		pedra	600.403
		gris	600.404
		negro	600.445
		negro	600.446

toja TOP 1/ *Blanco*

estructura	pata	color	cód.
BLANCO 160 cm. • 240 cm.		negro	600.372
		blanco	600.370
		pedra	600.373
		gris	600.374
160 X 90		negro	600.417
		blanco	600.416
		pedra	600.418
		gris	600.419
		negro	600.451
		negro	600.452

toja TOP 1/ *Blanco*

estructura	pata	color	cód.
BLANCO 180 cm. • 260 cm.		negro	600.322
		blanco	600.320
		pedra	600.323
		gris	600.324
180 X 100		negro	600.432
		blanco	600.431
		pedra	600.433
		gris	600.434
		negro	600.457
		negro	600.458

Toja TOP 2 MARRÓN



Toja pata A
TOP 2 marrón

toja TOP 2 / Marrón

estructura	pata	color	cód.
<p>140 cm. • 210 cm.</p>	X	negro	600.387
		blanco	600.388
		pedra	600.385
		gris	600.389
	V	negro	600.407
		blanco	600.406
		pedra	600.408
		gris	600.409
	O	negro	600.447
		negro	600.448
	A	negro	600.448

140
X
90

toja TOP 2 / Marrón

estructura	pata	color	cód.
<p>160 cm. • 240 cm.</p>	X	negro	600.382
		blanco	600.383
		pedra	600.380
		gris	600.384
	V	negro	600.422
		blanco	600.421
		pedra	600.423
		gris	600.424
	O	negro	600.453
		negro	600.454
	A	negro	600.454

160
X
90

toja TOP 2 / Marrón

estructura	pata	color	cód.
<p>180 cm. • 260 cm.</p>	X	negro	600.327
		blanco	600.328
		pedra	600.325
		gris	600.329
	V	negro	600.437
		blanco	600.436
		pedra	600.438
		gris	600.439
	O	negro	600.459
		negro	600.460
	A	negro	600.460

180
X
100

Toja TOP3 GRIS



GRUPO muebles
INTERMOBEL

Toja pata X gris
TOP 3 gris

toja TOP 3 / Gris

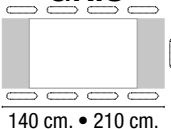
estructura	pata	color	cód.
 140 cm. • 210 cm.	X	negro	600.397
		blanco	600.398
		pedra	600.399
		gris	600.395
	V	negro	600.412
		blanco	600.411
		pedra	600.413
		gris	600.414
	O	negro	600.449
		negro	600.450

toja TOP 3 / Gris

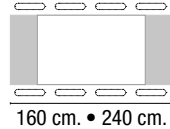
estructura	pata	color	cód.
 160 cm. • 240 cm.	X	negro	600.392
		blanco	600.393
		pedra	600.394
		gris	600.390
	V	negro	600.427
		blanco	600.426
		pedra	600.428
		gris	600.429
	O	negro	600.455
		negro	600.456

toja TOP 3 / Gris

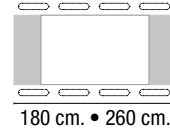
estructura	pata	color	cód.
 180 cm. • 260 cm.	X	negro	600.332
		blanco	600.333
		pedra	600.334
		gris	600.330
	V	negro	600.442
		blanco	600.441
		pedra	600.443
		gris	600.444
	O	negro	600.461
		negro	600.462

Redox TOP4 IBIZA



Redox
TOP 4 Ibiza

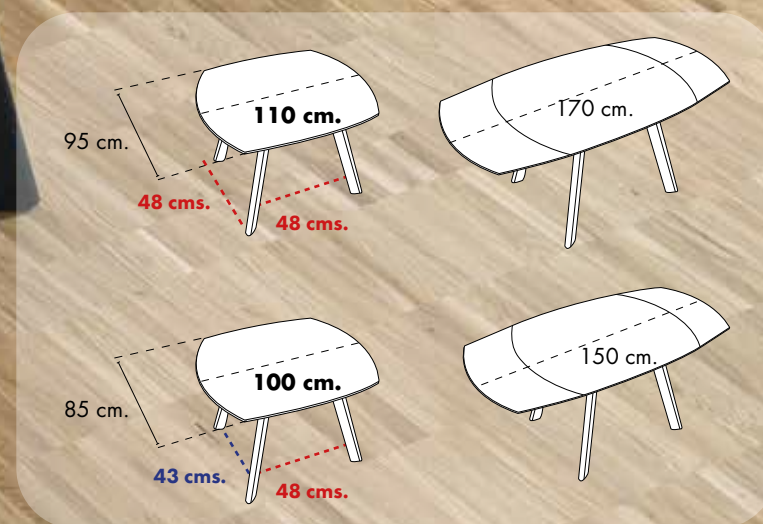

sistema apertura *fácil* mesa Redox



www.mesaredox.com

muebles
INTERMOBEL

redox TOP4 *Ibiza* 110x95

ref.	patas	estructura	sobre
600.214	negro	negro	top4/ibiza
600.224	blanco	negro	top4/ibiza

redox TOP4 *Ibiza* 100x85

ref.	patas	estructura	sobre
600.260	negro	negro	top4/ibiza
600.265	blanco	negro	top4/ibiza

MESA OVALADA EXTENSIBLE - 2 ALAS 110 x 95 ó 100 x 85

Redox TOP5 TIGRE

TOP HPL



Redox
TOP 5 Tigre



redox TOP5 / Tigre

110x95

ref.	patas	estructura	sobre
600.215	negro	negro	top5/tigre
600.225	blanco	negro	top5/tigre

redox TOP5 / Tigre

100x85

ref.	patas	estructura	sobre
600.261	negro	negro	top5/tigre
600.266	blanco	negro	top5/tigre

Redox TOP6 PIZARRA



Redox
TOP 6 pizarra



redox TOP6 / *Pizarra*

110x95

ref.	patas	estructura	sobre
600.216	negro	negro	top6/pizarra
600.226	blanco	negro	top6/pizarra

100x85

ref.	patas	estructura	sobre
600.262	negro	negro	top6/pizarra
600.267	blanco	negro	top6/pizarra

GRUPO **INTERMOBEL**

MESA OVALADA EXTENSIBLE - 2 ALAS 110 x 95 ó 100 x 85

Redox TOP7 GRANITO

TOP HPL



Redox
TOP 7 granito

redox TOP7 / Granito

110x95

ref.	patas	estructura	sobre
600.217	negro	negro	top7/granito
600.227	blanco	negro	top7/granito

100x85

ref.	patas	estructura	sobre
600.263	negro	negro	top7/granito
600.268	blanco	negro	top7/granito

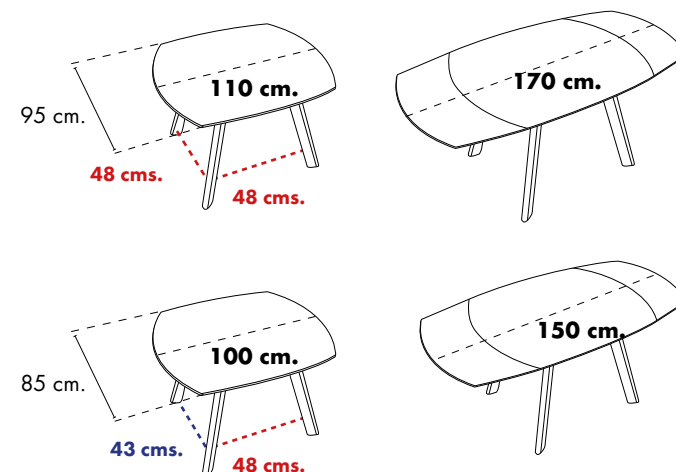

MESA OVALADA EXTENSIBLE - 2 ALAS 110 x 95 ó 100 x 85

Redox

110x95 CR BLANCO



Redox
Cristal Extra Blanco

GRUPO **INTERMOBEL**

redox *Cristal extra blanco*

110x95

ref.	patas	estructura	sobre
600.250	blanco	blanco	extra blanco
600.251	negro	blanco	extra blanco

MESA OVALADA EXTENSIBLE - 2 ALAS 110x95

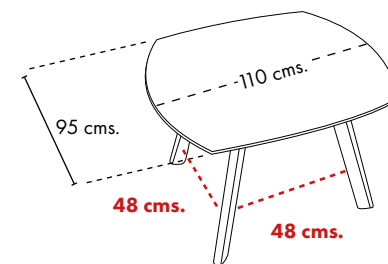
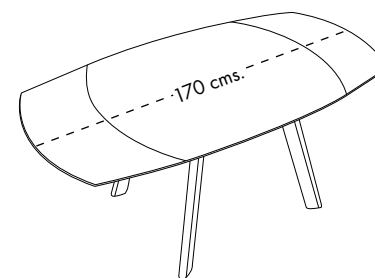

Redox

100x85 CR BLANCO

CRISTAL BLANCO



redox *Cristal extra blanco*

100x85

ref.	patas	estructura	sobre
600.255	blanco	blanco	extra blanco
600.256	negro	blanco	extra blanco

MESA OVALADA EXTENSIBLE - 2 ALAS 100 x 85

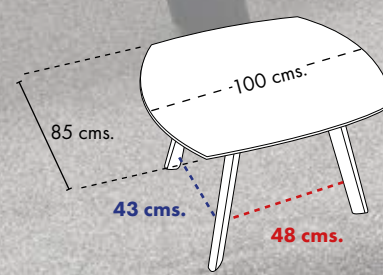
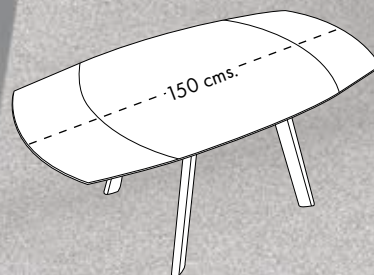

MC Siri TOP



siri pata negro

ref.	patas	sobre
861.721	negro	top1/blanco
861.722	negro	top2/marrón
861.723	negro	top3/gris
861.724	negro	top4/ibiza
861.725	negro	top5/tigre
861.726	negro	top6/pizarra
861.727	negro	top7/granito

siri pata blanco

ref.	patas	sobre
861.621	blanco	top1/blanco
861.622	blanco	top2/marrón
861.623	blanco	top3/gris
861.624	blanco	top4/ibiza
861.625	blanco	top5/tigre
861.626	blanco	top6/pizarra
861.627	blanco	top7/granito

siri pata piedra

ref.	patas	sobre
861.821	pedra	top1/blanco
861.822	pedra	top2/marrón
861.823	pedra	top3/gris
861.824	pedra	top4/ibiza
861.825	pedra	top5/tigre
861.826	pedra	top6/pizarra
861.827	pedra	top7/granito

siri pata gris

ref.	patas	sobre
861.921	gris	top1/blanco
861.922	gris	top2/marrón
861.923	gris	top3/gris
861.924	gris	top4/ibiza
861.925	gris	top5/tigre
861.926	gris	top6/pizarra
861.927	gris	top7/granito

MC Elevable TOP



Estructura Negra

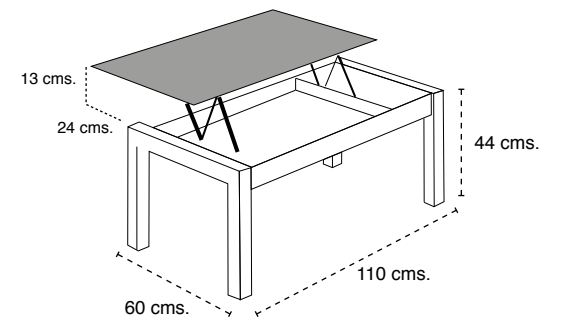

Estructura Negra

GRUPO muebles **INTERMOBEL**

Mesa Malta
Estructura negro
Pata negra
TOP 7 Granito

m.c. Malta elevable pata negro

ref.	patas	sobre
841.721	negro	top1/blanco
841.722	negro	top2/marrón
841.723	negro	top3/gris
841.724	negro	top4/ibiza
841.725	negro	top5/tigre
841.726	negro	top6/pizarra
841.727	negro	top7/granito

m.c. Malta elevable. pata blanco

ref.	patas	sobre
841.621	blanco	top1/blanco
841.622	blanco	top2/marrón
841.623	blanco	top3/gris
841.624	blanco	top4/ibiza
841.625	blanco	top5/tigre
841.626	blanco	top6/pizarra
841.627	blanco	top7/granito

m.c. Malta elevable. pata piedra

ref.	patas	sobre
841.821	piedra	top1/blanco
841.822	piedra	top2/marrón
841.823	piedra	top3/gris
841.824	piedra	top4/ibiza
841.825	piedra	top5/tigre
841.826	piedra	top6/pizarra
841.827	piedra	top7/granito

m.c. Malta elevable. pata gris

ref.	patas	sobre
841.921	gris	top1/blanco
841.922	gris	top2/marrón
841.923	gris	top3/gris
841.924	gris	top4/ibiza
841.925	gris	top5/tigre
841.926	gris	top6/pizarra
841.927	gris	top7/granito



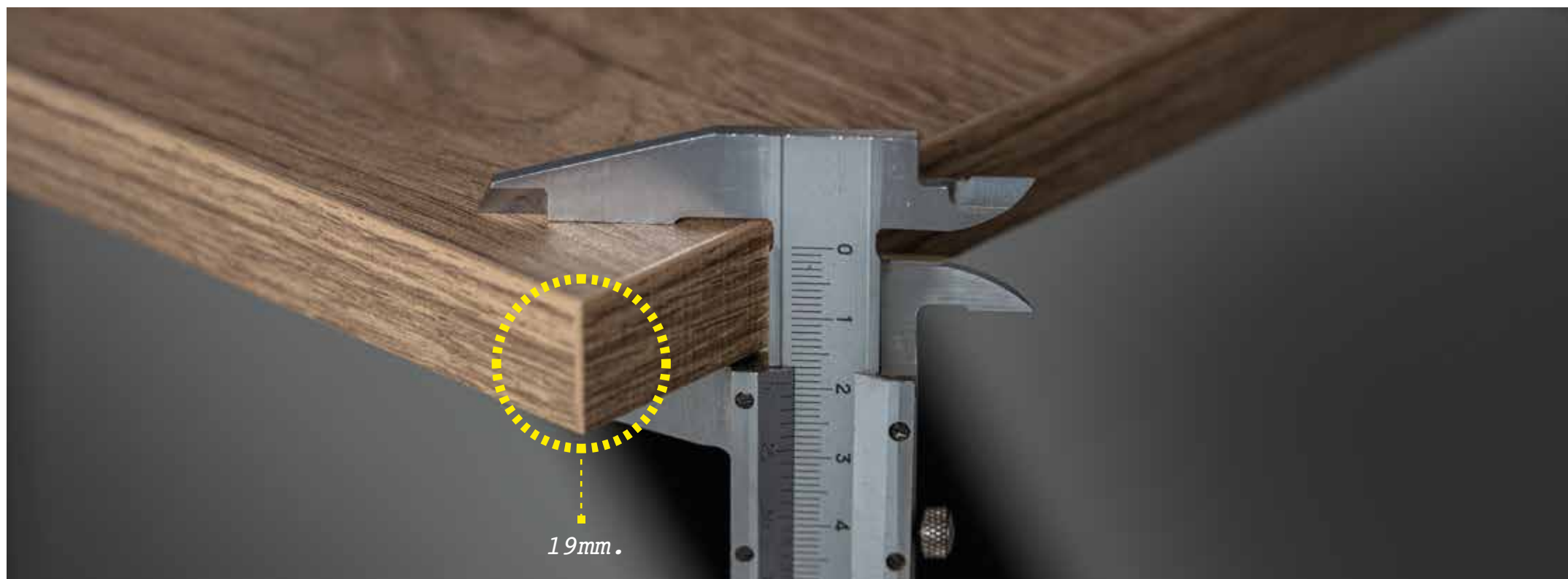

MELAMINA

Es un tablero conformado por partículas de madera con recubrimiento de diseños distintos y con un acabado de resina melamínica. La resina aporta una superficie totalmente uniforme sobre los tableros de conglomerado. La melamina es un ma-

terial no poroso, duro y resistente, gracias a ello, para su mantenimiento usar un trapo húmedo, ya sea en una solución de agua con detergente suave. No permite el desarrollo de microorganismos ni parásitos.

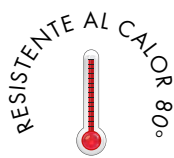

MUEBLES
INTERMOBEL



FOREST NIAGARA



FOREST NATURE



FOREST TABAK



FOREST BOREAL









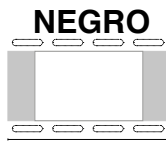

ADVERTENCIA: Se recomienda NO aplicar sobre la superficie de MELAMINA ollas, sartenes o cualquier objeto que haya estado en contacto con el fuego o a altas temperaturas.







Forest NIAGARA CANTO NEGRO

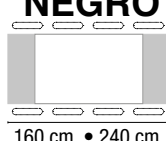

forest Niagara Canto Negro

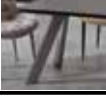
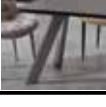
estructura	pata	color	cód.
 NEGRO 140 cm. • 210 cm.		negro	941.733
		blanco	941.633
		pedra	941.833
		gris	941.933
		negro	942.733
		blanco	942.633
		pedra	942.833
		gris	942.933
		negro	943.733
		negro	944.733

forest Niagara Canto Negro

estructura	pata	color	cód.
 NEGRO 160 cm. • 240 cm.		negro	961.733
		blanco	961.633
		pedra	961.833
		gris	961.933
		negro	962.733
		blanco	962.633
		pedra	962.833
		gris	962.933
		negro	963.733
		negro	964.733

GRUPO **muebles**
INTERMOBEL

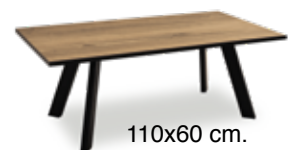

forest Canto Negro / M.C. fija

ref.	patas	sobre
861.733	negro	niagara
861.633	blanco	niagara
861.833	pedra	niagara
861.933	gris	niagara



forest Canto Negro / M.C. elevable

ref.	patas	estructura	sobre
841.733	negro	negro	niagara
841.633	blanco	negro	niagara
841.833	pedra	negro	niagara
841.933	gris	negro	niagara

Forest
Niagara

Forest NIAGARA CANTO MADERA



forest Niagara Canto Madera

estructura	pata	color	cód.
<p>140 cm. • 210 cm.</p> <p>140 X 90</p>	X	negro	941.753
		blanco	941.653
		pedra	941.853
		gris	941.953
		negro	942.753
	V	blanco	942.653
		pedra	942.853
		gris	942.953
		negro	943.753
	O	negro	943.753
		negro	944.753
	A	negro	944.753

forest Niagara Canto Madera

estructura	pata	color	cód.
<p>160 cm. • 240 cm.</p> <p>160 X 90</p>	X	negro	961.753
		blanco	961.653
		pedra	961.853
		gris	961.953
		negro	962.753
	V	blanco	962.653
		pedra	962.853
		gris	962.953
		negro	963.753
	O	negro	963.753
		negro	964.753
	A	negro	964.753

forest Canto Madera/M.C. fija

ref.	patas	sobre
861.753	negro	niagara
861.653	blanco	niagara
861.853	pedra	niagara
861.953	gris	niagara



110x60 cm.



110x60 cm.

forest Canto Madera/elevable

ref.	patas	sobre
841.753	negro	niagara
841.653	blanco	niagara
841.853	pedra	niagara
841.953	gris	niagara

forest

NATURE CANTO NEGRO



Forest
Nature

forest Nature Canto Negro

estructura	pata	color	cód.
 140 cm. • 210 cm.		negro	941.731
		blanco	941.631
		pedra	941.831
		gris	941.931
		V	negro
		blanco	942.631
		pedra	942.831
		gris	942.931
		O	negro
		negro	943.731
		A	negro
		negro	944.731
		A	negro

140
X
90

forest Nature Canto Negro

estructura	pata	color	cód.
 160 cm. • 240 cm.		negro	961.731
		blanco	961.631
		pedra	961.831
		gris	961.931
		V	negro
		blanco	962.631
		pedra	962.831
		gris	962.931
		O	negro
		negro	963.731
		A	negro
		negro	964.731
		A	negro

160
X
90

forest Canto Negro/M.C. fija

ref.	patas	sobre
861.730	negro	nature
861.630	blanco	nature
861.830	pedra	nature
861.930	gris	nature



110x60 cm.



110x60 cm.

forest Canto Negro/elevable

ref.	patas	sobre
841.730	negro	nature
841.630	blanco	nature
841.830	pedra	nature
841.930	gris	nature

forest

NATURE CANTO MADERA

GRUPO MUEBLES
INTERMOBEL

forest Nature Canto Madera

estructura	pata	color	cód.
NEGRO  140 cm. • 210 cm.	X	negro	941.751
		blanco	941.651
		pedra	941.851
	gris	941.951	
	V	negro	942.751
	blanco	942.651	
	pedra	942.851	
	gris	942.951	
140 X 90	O		
		negro	943.751
	A		
	negro	944.751	

forest Nature Canto Madera

estructura	pata	color	cód.
NEGRO  160 cm. • 240 cm.	X	negro	961.751
		blanco	961.651
		pedra	961.851
	gris	961.951	
	V	negro	962.751
	blanco	962.651	
	pedra	962.851	
	gris	962.951	
160 X 90	O		
		negro	963.751
	A		
	negro	964.751	

forest Canto Madera / M.C. fija

ref.	patas	sobre
861.751	negro	nature
861.651	blanco	nature
861.851	pedra	nature
861.951	gris	nature



110x60 cm.



110x60 cm.

forest Canto Madera / elevable

ref.	patas	sobre
841.751	negro	nature
841.651	blanco	nature
841.851	pedra	nature
841.951	gris	nature

MELAMINA

forest

TABAK CANTO NEGRO



forest **Tabak** Canto Negro

estructura	pata	color	cód.
 140 cm. • 210 cm.		negro	941.734
		blanco	941.634
		pedra	941.834
		gris	941.934
 140 X 90		negro	942.734
		blanco	942.634
		pedra	942.834
		gris	942.934
		negro	943.734
		negro	944.734

forest **Tabak** Canto Negro

estructura	pata	color	cód.
 160 cm. • 240 cm.		negro	961.734
		blanco	961.634
		pedra	961.834
		gris	961.934
 160 X 90		negro	962.734
		blanco	962.634
		pedra	962.834
		gris	962.934
		negro	963.734
		negro	964.734

forest Canto Negro/M.C. fija

ref.	patas	sobre
861.734	negro	tabak
861.634	blanco	tabak
861.834	pedra	tabak
861.934	gris	tabak



forest Canto Negro/elevable

ref.	patas	sobre
841.734	negro	tabak
841.634	blanco	tabak
841.834	pedra	tabak
841.934	gris	tabak

forest

TABAK CANTO MADERA

forest **Tabak** Canto Madera

estructura	pata	color	cód.	
NEGRO  140 cm. • 210 cm.	X	negro	941.754	
		blanco	941.654	
		pedra	941.854	
		gris	941.954	
		V	negro	942.754
		blanco	942.654	
		pedra	942.854	
		gris	942.954	
		O	negro	943.754
		A	negro	944.754
				

forest **Tabak** Canto Madera

estructura	pata	color	cód.	
NEGRO  160 cm. • 240 cm.	X	negro	961.754	
		blanco	961.654	
		pedra	961.854	
		gris	961.954	
		V	negro	962.754
		blanco	962.654	
		pedra	962.854	
		gris	962.954	
		O	negro	963.754
		A	negro	964.754
				

forest Canto Madera / M.C. fija

ref.	patas	sobre
861.754	negro	tabak
861.654	blanco	tabak
861.854	pedra	tabak
861.954	gris	tabak



forest Canto Madera/elevable





ref.	patas	sobre
841.754	negro	tabak
841.654	blanco	tabak
841.854	pedra	tabak
841.954	gris	tabak

Forest

BOREAL CANTO NEGRO







forest Boreal Canto Negro

estructura	pata	color	cód.
 140 cm. • 210 cm.		negro	941.732
		blanco	941.632
		pedra	941.832
		gris	941.932
	V	negro	942.732
	blanco	942.632	
	pedra	942.832	
	gris	942.932	
O	negro	943.732	
	negro	944.732	
	A	negro	944.732
	negro	944.732	

140
X
90

forest Boreal Canto Negro

estructura	pata	color	cód.
 160 cm. • 240 cm.		negro	961.732
		blanco	961.632
		pedra	961.832
		gris	961.932
	V	negro	962.732
	blanco	962.632	
	pedra	962.832	
	gris	962.932	
O	negro	963.732	
	negro	964.732	
	A	negro	964.732
	negro	964.732	

160
X
90

forest Canto Negro/M.C. fija

ref.	patas	sobre
861.732	negro	boreal
861.632	blanco	boreal
861.832	pedra	boreal
861.932	gris	boreal



forest Canto Negro/elevable

ref.	patas	sobre
841.732	negro	boreal
841.632	blanco	boreal
841.832	pedra	boreal
841.932	gris	boreal

forest

BOREAL CANTO MADERA



forest Boreal Canto Madera

estructura	pata	color	cód.
<p>140 cm. • 210 cm.</p> <p>140 X 90</p>	X	negro	941.752
		blanco	941.652
		pedra	941.852
		gris	941.952
	V	negro	942.752
		blanco	942.652
		pedra	942.852
		gris	942.952
	O	negro	943.752
		A	negro

forest Boreal Canto Madera

estructura	pata	color	cód.
<p>160 cm. • 240 cm.</p> <p>160 X 90</p>	X	negro	961.752
		blanco	961.652
		pedra	961.852
		gris	961.952
	V	negro	962.752
		blanco	962.652
		pedra	962.852
		gris	962.952
	O	negro	963.752
		A	negro

forest Canto Madera / M.C. fija

ref.	patas	sobre
861.752	negro	boreal
861.652	blanco	boreal
861.852	pedra	boreal
861.952	gris	boreal



forest Canto Madera / elevable

ref.	patas	sobre
841.752	negro	boreal
841.652	blanco	boreal
841.852	pedra	boreal
841.952	gris	boreal

	Serie	Pag.
B	<i>Bea</i>	58
	<i>Bea África</i>	66
	<i>Bea Belfast</i>	60
	<i>Bea Brido</i>	62
	<i>Bea Magnum</i>	64
	<i>Bea Ruedas</i>	68
C	<i>Celín</i>	114
	<i>Celín África</i>	120
	<i>Celín Belfast</i>	116
	<i>Celín Brido</i>	118
	<i>Concha</i>	88
	<i>Concha Brido</i>	90
D	<i>Duna</i>	108
	<i>Duna África</i>	113
	<i>Duna Belfast</i>	110
	<i>Duna Brido</i>	112
E	<i>Emy</i>	92
	<i>Emy Belfast</i>	94
	<i>Emy Magnum</i>	96



Composición Tapizados

	BRIDO	BELFAST
Composición	100% poliéster	95% poliéster + 5% nylon
Peso	360 gr./m ²	370 gr./m ²
Abrasión ciclos	> 40.000	> 40.000
Pilling	5,0	5,0
	Waterproof - Teflón	Waterproof



	Serie	Pag.
L	<i>Leti</i>	78
	<i>Leti África</i>	86
	<i>Leti Belfast</i>	80
	<i>Leti Brido</i>	82
	<i>Leti Magnum</i>	84
M	<i>Mia</i>	98
	<i>Mia África</i>	106
	<i>Mia Belfast</i>	100
	<i>Mia Brido</i>	102
	<i>Mia Magnum</i>	104
N	<i>Nela</i>	52
	<i>Nela Belfast</i>	54
	<i>Nela Magnum</i>	56
	<i>Nela Ruedas</i>	69
R	<i>Ryta</i>	70
	<i>Ryta Belfast</i>	72
	<i>Ryta Brido</i>	74
	<i>Ryta Magnum</i>	76

Composición Tapizados

	ÁFRICA	MAGNUM
Composición	65% poliuretano 15% algodón 20% poliéster	12% poliuretano 88% algodón
Grosor	1,1 mm.	1,2 mm.
Abrasión ciclos	> 50.000	> 50.000
Hydrolisis	4	5
	Waterproof	Waterproof transpirable

Tapizados

BELFAST

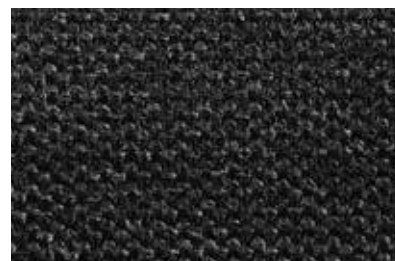

NEGRO F16



GRIS F14



PARDO F04



CORAL F36



AMARILLO F44



MENTA F46



VERDE F37

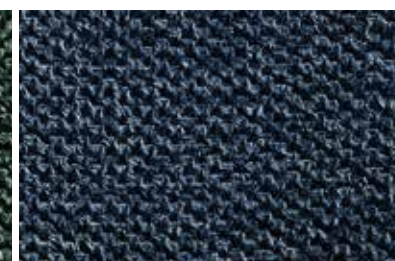

AZULÓN F38

MAGNUM



M1



M3



M4



M5



M6

Nela

MUEBLES
INTERMOBEL



Nela

muebles
INTERMOBEL

BELFAST



NEGRO F16



GRIS F14



pata Negro

ref.	asiento	pata
603.440	pardo F-04	negro
603.441	gris F-14	negro
603.442	negro F-16	negro
603.443	verde F-37	negro
603.444	azulón F-38	negro
603.445	amarillo F-44	negro
603.446	coral F-36	negro
603.447	menta F-46	negro

pata Blanco

ref.	asiento	pata
603.820	pardo F-04	blanco
603.821	gris F-14	blanco
603.822	negro F-16	blanco
603.823	verde F-37	blanco
603.824	azulón F-38	blanco
603.825	amarillo F-44	blanco
603.826	coral F-36	blanco
603.827	menta F-46	blanco

pata Piedra

ref.	asiento	pata
603.834	pardo F-04	piedra
603.835	gris F-14	piedra
603.836	negro F-16	piedra
603.837	verde F-37	piedra
603.838	azulón F-38	piedra
603.839	amarillo F-44	piedra
603.840	coral F-36	piedra
603.841	menta F-46	piedra

pata Gris

ref.	asiento	pata
603.848	pardo F-04	gris
603.849	gris F-14	gris
603.850	negro F-16	gris
603.851	verde F-37	gris
603.852	azulón F-38	gris
603.853	amarillo F-44	gris
603.854	coral F-36	gris
603.855	menta F-46	gris



PARDO F04



CORAL F36



AMARILLO F44



MENTA F46



VERDE F37

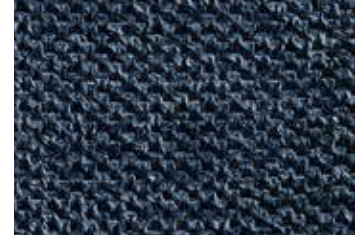

AZULÓN F38



pata Cromo brillo

ref.	asiento	pata
603.806	pardo F-04	cromo
603.807	gris F-14	cromo
603.808	negro F-16	cromo
603.809	verde F-37	cromo
603.810	azulón F-38	cromo
603.811	amarillo F-44	cromo
603.812	coral F-36	cromo
603.813	menta F-46	cromo

pata Símil roble

ref.	asiento	pata
503.806	pardo F-04	símil roble
503.807	gris F-14	símil roble
503.808	negro F-16	símil roble
503.809	verde F-37	símil roble
503.810	azulón F-38	símil roble
503.811	amarillo F-44	símil roble
503.812	coral F-36	símil 212
503.813	menta F-46	símil roble

GRUPO **muebles**
INTERMOBEL



Opción ruedas, pag. 68

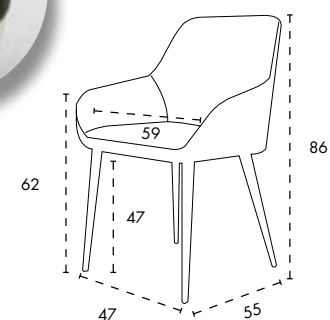



pata negro

REF.	ASIENTO	PATA
603.430	M-1	negro
603.431	M-3	negro
603.432	M-4	negro
603.433	M-5	negro
603.434	M-6	negro
603.435	tela cliente	negro

pata blanco

REF.	ASIENTO	PATA
603.814	M-1	blanco
603.815	M-3	blanco
603.816	M-4	blanco
603.817	M-5	blanco
603.818	M-6	blanco
603.819	tela cliente	blanco

pata piedra

REF.	ASIENTO	PATA
603.828	M-1	piedra
603.829	M-3	piedra
603.830	M-4	piedra
603.831	M-5	piedra
603.832	M-6	piedra
603.833	tela cliente	piedra

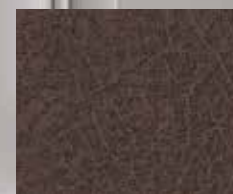

M1

M3

M4

M5

M6

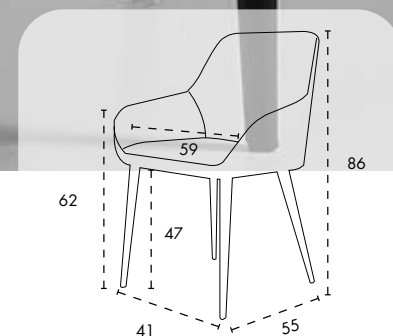

muebles
INTERMOBEL

Opción ruedas, pag. 68

pata
gris

REF.	ASIENTO	PATA	PUNTOS
603.842	M-1	gris	
603.843	M-3	gris	
603.844	M-4	gris	
603.845	M-5	gris	
603.846	M-6	gris	
603.847	tela cliente	gris	

pata
cromo brillo

REF.	ASIENTO	PATA
603.800	M-1	cromo
603.801	M-3	cromo
603.802	M-4	cromo
603.803	M-5	cromo
603.804	M-6	cromo
603.805	tela cliente	cromo

pata
símil roble

REF.	ASIENTO	PATA
503.800	M-1	símil roble
503.801	M-3	símil roble
503.802	M-4	símil roble
503.803	M-5	símil roble
503.804	M-6	símil roble
503.805	tela cliente	símil roble

Tapizados

BELFAST



NEGRO F16



GRIS F14



PARDO F04



CORAL F36



AMARILLO F44



MENTA F46



VERDE F37

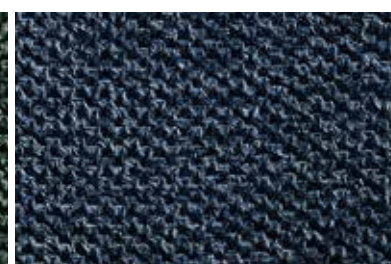

AZULÓN F38

TELA BRIDO

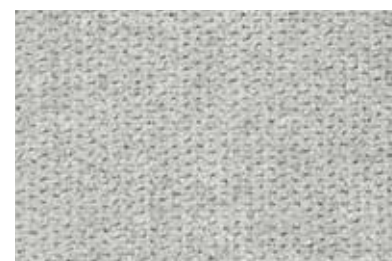

B5 Grey



B7 Camel



B8 Tabac

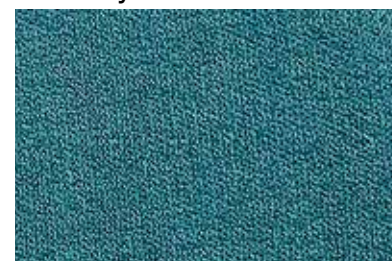

B10 Turquesa



B12 Ash



B6 Mostaza

ÁFRICA

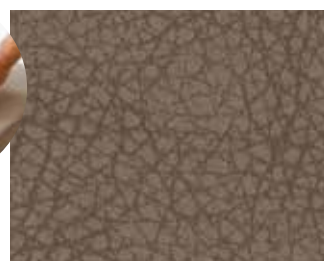

A2 Humo



A3 Blanco

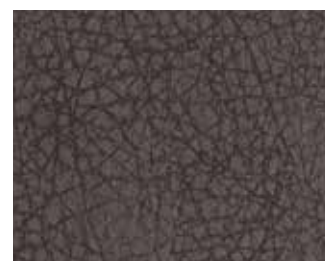

A4 Roca



A5 Crema



A12 Ceniza



A14 Azul

MAGNUM

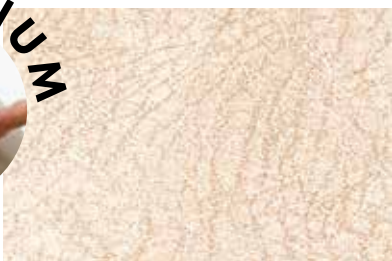

M1



M3



M4



M5



M6



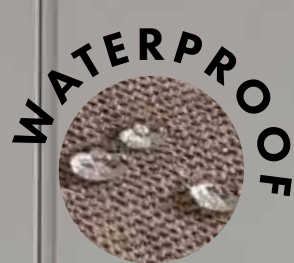

NEGRO F16
Detalle gris



GRIS F14
Detalle negro



pata Negro

ref.	asiento	pata
603.460	pardo F-04	negro
603.461	gris F-14	negro
603.462	negro F-16	negro
603.463	verde F-37	negro
603.464	azulón F-38	negro
603.465	amarillo F-44	negro
603.466	coral F-36	negro
603.467	menta F-46	negro

pata Blanco

ref.	asiento	pata
603.450	pardo F-04	blanco
603.451	gris F-14	blanco
603.452	negro F-16	blanco
603.453	verde F-37	blanco
603.454	azulón F-38	blanco
603.455	amarillo F-44	blanco
603.456	coral F-36	blanco
603.457	menta F-46	blanco

pata Piedra

ref.	asiento	pata
603.470	pardo F-04	piedra
603.471	gris F-14	piedra
603.472	negro F-16	piedra
603.473	verde F-37	piedra
603.474	azulón F-38	piedra
603.475	amarillo F-44	piedra
603.476	coral F-36	piedra
603.477	menta F-46	piedra

pata Gris

ref.	asiento	pata
603.480	pardo F-04	gris
603.481	gris F-14	gris
603.482	negro F-16	gris
603.483	verde F-37	gris
603.484	azulón F-38	gris
603.485	amarillo F-44	gris
603.486	coral F-36	gris
603.487	menta F-46	gris



PARDO F04
Detalle negro



CORAL F36
Detalle negro



AMARILLO F44
Detalle negro



MENTA F46
Detalle negro



VERDE F37
Detalle negro



AZULÓN F38
Detalle negro



pata Cromo brillo

ref.	asiento	pata
603.490	pardo F-04	cromo
603.491	gris F-14	cromo
603.492	negro F-16	cromo
603.493	verde F-37	cromo
603.494	azulón F-38	cromo
603.495	amarillo F-44	cromo
603.496	coral F-36	cromo
603.497	menta F-46	cromo

pata Símil roble

ref.	asiento	pata
503.490	pardo F-04	símil roble
503.491	gris F-14	símil roble
503.492	negro F-16	símil roble
503.493	verde F-37	símil roble
503.494	azulón F-38	símil roble
503.495	amarillo F-44	símil roble
503.496	coral F-36	símil roble
503.497	menta F-46	símil roble

muebles
INTERMOBEL



Opción ruedas, pag. 68

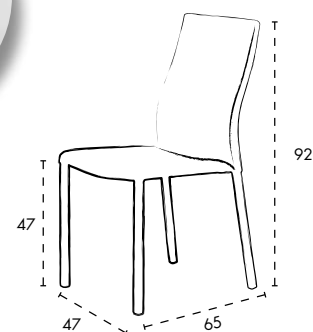



patas
negro

REF.	ASIENTO	PATA
602.860	grey B-5	negro
602.861	ash B-12	negro
602.862	tabac B-8	negro
602.863	camel B-7	negro
602.864	turquesa B-10	negro
602.865	mostaza B-6	negro

patas
blanco

REF.	ASIENTO	PATA
602.850	grey B-5	blanco
602.851	ash B-12	blanco
602.852	tabac B-8	blanco
602.853	camel B-7	blanco
602.854	turquesa B-10	blanco
602.855	mostaza B-6	blanco

patas
pedra

REF.	ASIENTO	PATA
602.870	grey B-5	pedra
602.871	ash B-12	pedra
602.872	tabac B-8	pedra
602.873	camel B-7	pedra
602.874	turquesa B-10	pedra
602.875	mostaza B-6	pedra



B-5 GREY



B-7 CAMEL



B-8 TABAC



B-10 TURQUESA

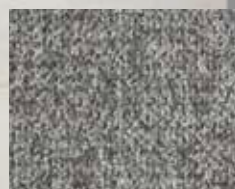

B-12 ASH



B-6 MOSTAZA



Opción ruedas, pag. 68

ASIENTO+RESP.	DETALLE
grey B-5	ash B-12
mostaza B-6	ash B-12
camel B-7	tabac B-8
tabac B-8	camel B-7
turquesa B-10	ash B-12
ash B-12	grey B-5

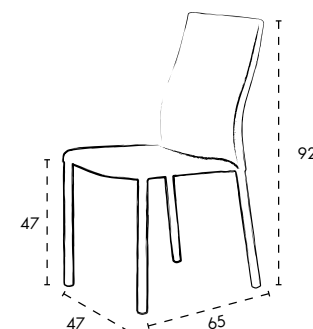

patas gris

REF.	ASIENTO	PATA
602.880	grey B-5	gris
602.881	ash B-12	gris
602.882	tabac B-8	gris
602.883	camel B-7	gris
602.884	turquesa B-10	gris
602.885	mostaza B-6	gris

patas cromo brillo

REF.	ASIENTO	PATA
602.910	grey B-5	cromo
602.911	ash B-12	cromo
602.912	tabac B-8	cromo
602.913	camel B-7	cromo
602.914	turquesa B-10	cromo
602.915	mostaza B-6	cromo

patas símil roble

REF.	ASIENTO	PATA
503.910	grey B-5	símil roble
503.911	ash B-12	símil roble
503.912	tabac B-8	símil roble
503.913	camel B-7	símil roble
503.914	turquesa B-10	símil roble
503.915	mostaza B-6	símil roble



Silla BEA |

pata
negro

REF.	ASIENTO	PATA
601.765	M-1	negro
601.766	M-3	negro
601.767	M-4	negro
601.768	M-5	negro
601.769	M-6	negro

pata
blanco

REF.	ASIENTO	PATA
601.760	M-1	blanco
601.761	M-3	blanco
601.762	M-4	blanco
601.763	M-5	blanco
601.764	M-6	blanco

pata
pedra

REF.	ASIENTO	PATA
601.770	M-1	pedra
601.771	M-3	pedra
601.772	M-4	pedra
601.773	M-5	pedra
601.774	M-6	pedra



Opción ruedas, pag. 68

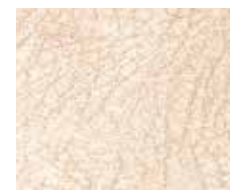

M1



M3



M4



M5



M6

GRUP muebles
INTERMOBEL



ASIENTO	DETALLE
M-1	M-3
M-3	M-1
M-4	M-5
M-5	M-4
M-6	M-5

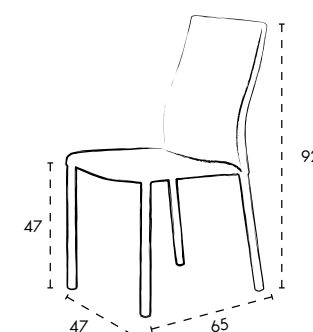

pata gris

REF.	ASIENTO	PATA
601.775	M-1	gris
601.776	M-3	gris
601.777	M-4	gris
601.778	M-5	gris
601.779	M-6	gris

pata cromo brillo

REF.	ASIENTO	PATA
601.780	M-1	cromo
601.781	M-3	cromo
601.782	M-4	cromo
601.783	M-5	cromo
601.784	M-6	cromo

pata símil roble

REF.	ASIENTO	PATA
503.780	M-1	simil roble
503.781	M-3	simil roble
503.782	M-4	simil roble
503.783	M-5	simil roble
503.784	M-6	simil roble



pata
negro

REF.	ASIENTO	PATA
601.660	blanco A-3	negro
601.661	humo A-2	negro
601.662	roca A-4	negro
601.663	crema A-5	negro
601.664	ceniza A-12	negro
601.666	azul A-14	negro
601.665	tela cliente	negro

pata
blanco

REF.	ASIENTO	PATA
601.650	blanco A-3	blanco
601.651	humo A-2	blanco
601.652	roca A-4	blanco
601.653	crema A-5	blanco
601.654	ceniza A-12	blanco
601.656	azul A-14	blanco
601.655	tela cliente	blanco

pata
pedra

REF.	ASIENTO	PATA
601.670	blanco A-3	pedra
601.671	humo A-2	pedra
601.672	roca A-4	pedra
601.673	crema A-5	pedra
601.674	ceniza A-12	pedra
601.676	azul A-14	pedra
601.675	tela cliente	pedra



Opción ruedas, pag. 68



A2 Humo



A3 Blanco

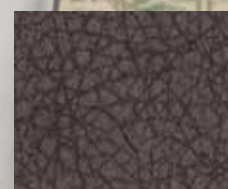

A4 Roca



A5 Crema



A12 Ceniza



A14 Azul



GRUPPO MUEBLES
INTERMOBEL

ASIENTO	DETALLE
blanco A-3	blanco A-3
humo A-2	crema A-5
roca A-4	ceniza A-12

ASIENTO	DETALLE
crema A-5	humo A-2
ceniza A-12	roca A-4
azul A-14	ceniza A-12

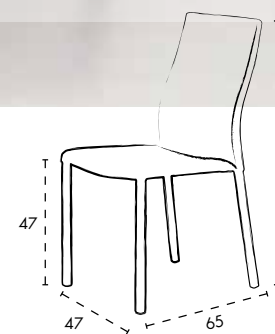

pata gris

REF.	ASIENTO	PATA
601.680	blanco A-3	gris
601.681	humo A-2	gris
601.682	roca A-4	gris
601.683	crema A-5	gris
601.684	ceniza A-12	gris
601.686	azul A-14	gris
601.685	tela cliente	gris

pata cromo brillo

REF.	ASIENTO	PATA
601.690	blanco A-3	cromo
601.691	humo A-2	cromo
601.692	roca A-4	cromo
601.693	crema A-5	cromo
601.694	ceniza A-12	cromo
601.696	azul A-14	cromo
601.695	tela cliente	cromo

pata símil roble

REF.	ASIENTO	PATA
503.750	blanco A-3	símil roble
503.751	humo A-2	símil roble
503.752	roca A-4	símil roble
503.753	crema A-5	símil roble
503.754	ceniza A-12	símil roble
503.756	azul A-14	símil roble
503.755	tela cliente	símil roble



Belfast

ref.	asiento	pata
602.490	pardo F-04	ruedas negro
602.491	gris F-14	ruedas negro
602.492	negro F-16	ruedas negro
602.493	verde F-37	ruedas negro
602.494	azulón F-38	ruedas negro
602.495	amarillo F-44	ruedas negro
602.496	coral F-36	ruedas negro
602.497	menta F-46	ruedas negro



Brido

ref.	asiento	pata
602.026	grey B-5	ruedas negro
602.027	ash B-12	ruedas negro
602.028	tabac B-8	ruedas negro
602.029	camel B-7	ruedas negro
602.030	turquesa B-10	ruedas negro
602.031	mostaza B-6	ruedas negro



Magnum

ref.	asiento	pata
602.032	M-1	ruedas negro
602.033	M-3	ruedas negro
602.034	M-4	ruedas negro
602.035	M-5	ruedas negro
602.036	M-6	ruedas negro



África

ref.	asiento	pata
602.020	blanco A-3	ruedas negro
602.021	humo A-2	ruedas negro
602.022	roca A-4	ruedas negro
602.023	crema A-5	ruedas negro
602.024	ceniza A-12	ruedas negro
602.025	azul A-14	ruedas negro
602.064	tela cliente	ruedas negro



Belfast

ref.	asiento	pata
603.862	pardo F-04	ruedas negro
603.863	gris F-14	ruedas negro
603.864	negro F-16	ruedas negro
603.865	verde F-37	ruedas negro
603.866	azulón F-38	ruedas negro
603.867	amarillo F-44	ruedas negro
603.868	coral F-36	ruedas negro
603.869	menta F-46	ruedas negro



Magnum

ref.	asiento	pata
603.856	M-1	ruedas negro
603.857	M-3	ruedas negro
603.858	M-4	ruedas negro
603.859	M-5	ruedas negro
603.860	M-6	ruedas negro
603.861	tela cliente	ruedas negro

Tapizados



NEGRO F16



GRIS F14



PARDO F04



CORAL F36



AMARILLO F44



MENTA F46



VERDE F37

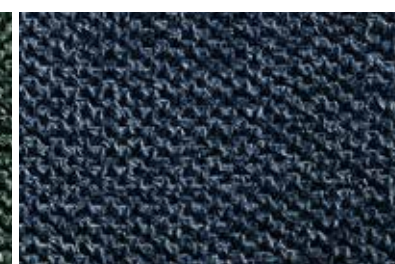

AZULÓN F38

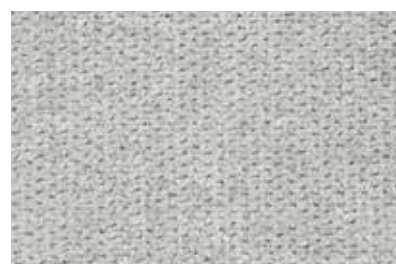

B5 Grey



B7 Camel



B8 Tabac

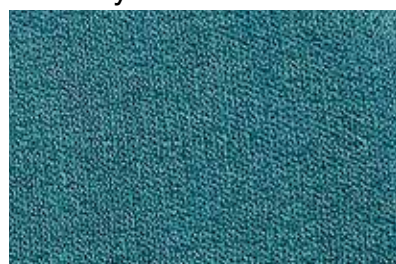

B10 Turquesa



B12 Ash



B6 Mostaza



M1



M3



M4



M5



M6

Ryta





NEGRO F16



GRIS F14





PARDO F04



CORAL F36



AMARILLO F44



MENTA F46



VERDE F37



AZULÓN F38



pata Negro

ref.	asiento	pata
603.420	pardo F-04	negro
603.421	gris F-14	negro
603.422	negro F-16	negro
603.423	verde F-37	negro
603.424	azulón F-38	negro
603.425	amarillo F-44	negro
603.426	coral F-36	negro
603.427	menta F-46	negro

pata Blanco

ref.	asiento	pata
603.532	pardo F-04	blanco
603.533	gris F-14	blanco
603.534	negro F-16	blanco
603.535	verde F-37	blanco
603.536	azulón F-38	blanco
603.537	amarillo F-44	blanco
603.538	coral F-36	blanco
603.539	menta F-46	blanco

GRUPO **muebles**
INTERMOBEL

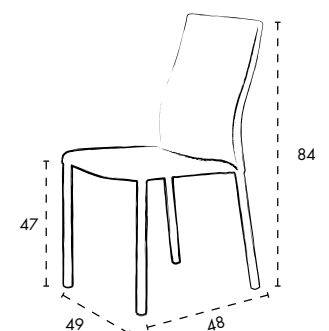



patas negro

REF.	ASIENTO	PATA
603.300	grey B-5	negro
603.301	ash B-12	negro
603.302	tabac B-8	negro
603.303	camel B-7	negro
603.304	turquesa B-10	negro
603.305	mostaza B-6	negro



B-5 GREY



B-7 CAMEL



B-8 TABAC



B-10 TURQUESA



B-12 ASH

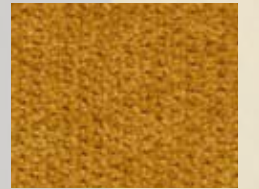

B-6 MOSTAZA



patas
blanco

REF.	ASIENTO	PATA
603.520	grey B-5	blanco
603.521	ash B-12	blanco
603.522	tabac B-8	blanco
603.523	camel B-7	blanco
603.524	turquesa B-10	blanco
603.525	mostaza B-6	blanco

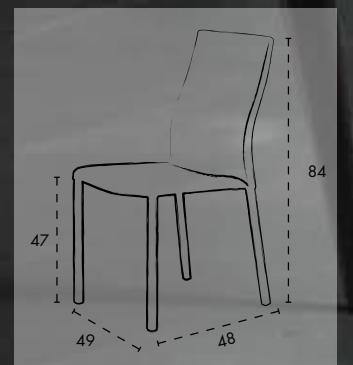

Ryta MAGNUM





M1

M3

M4

M5

M6



pata
negro

REF.	ASIENTO	PATA
603.410	M-1	negro
603.411	M-3	negro
603.412	M-4	negro
603.413	M-5	negro
603.414	M-6	negro
603.306	tela cliente	negro

pata
blanco

REF.	ASIENTO	PATA
603.527	M-1	blanco
603.528	M-3	blanco
603.529	M-4	blanco
603.530	M-5	blanco
603.531	M-6	blanco
603.526	tela cliente	blanco

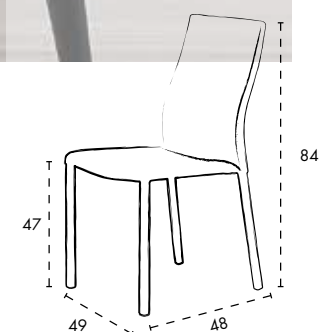

Tapizados

BELFAST



NEGRO F16



GRIS F14



PARDO F04



CORAL F36



AMARILLO F44



MENTA F46



VERDE F37

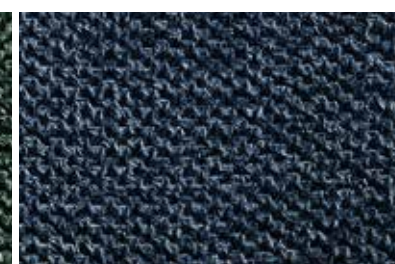

AZULÓN F38

TELA BRIDO

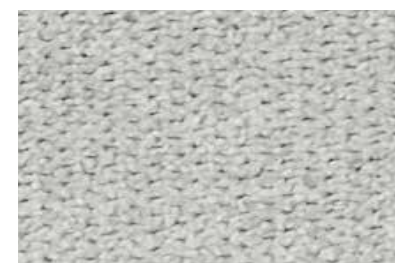

B5 Grey



B7 Camel



B8 Tabac

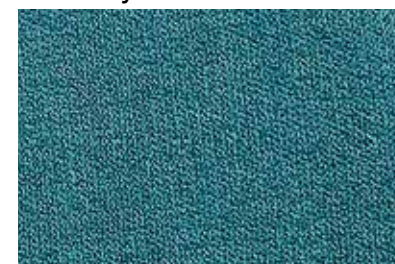

B10 Turquesa



B12 Ash



B6 Mostaza

MAGNUM



M1



M3



M4



M5



M6

ÁFRICA

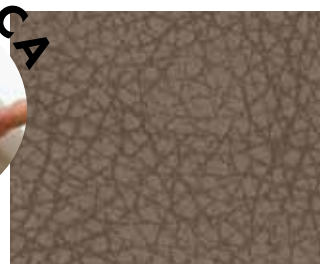

A2 Humo



A3 Blanco

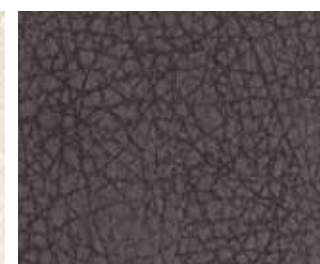

A4 Roca



A5 Crema



A12 Ceniza



A14 Azul



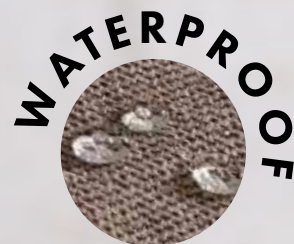

NEGRO F16



GRIS F14



pata Negro

ref.	asiento	pata
603.340	pardo F-04	negro
603.341	gris F-14	negro
603.342	negro F-16	negro
603.343	verde F-37	negro
603.344	azulón F-38	negro
603.345	amarillo F-44	negro
603.346	coral F-36	negro
603.347	menta F-46	negro

pata Blanco

ref.	asiento	pata
603.350	pardo F-04	blanco
603.351	gris F-14	blanco
603.352	negro F-16	blanco
603.353	verde F-37	blanco
603.354	azulón F-38	blanco
603.355	amarillo F-44	blanco
603.356	coral F-36	blanco
603.357	menta F-46	blanco

pata Piedra

ref.	asiento	pata
603.612	pardo F-04	piedra
603.613	gris F-14	piedra
603.614	negro F-16	piedra
603.615	verde F-37	piedra
603.616	azulón F-38	piedra
603.617	amarillo F-44	piedra
603.618	coral F-36	piedra
603.619	menta F-46	piedra

pata Gris

ref.	asiento	pata
603.632	pardo F-04	gris
603.633	gris F-14	gris
603.634	negro F-16	gris
603.635	verde F-37	gris
603.636	azulón F-38	gris
603.637	amarillo F-44	gris
603.638	coral F-36	gris
603.639	menta F-46	gris



PARDO F04



CORAL F36



AMARILLO F44



MENTA F46



VERDE F37

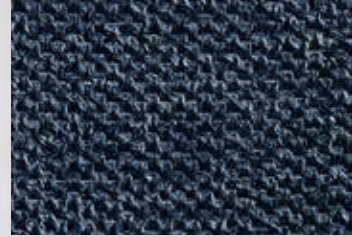

AZULÓN F38



pata Cromo brillo

ref.	asiento	pata
603.592	pardo F-04	cromo
603.593	gris F-14	cromo
603.594	negro F-16	cromo
603.595	verde F-37	cromo
603.596	azulón F-38	cromo
603.597	amarillo F-44	cromo
603.598	coral F-36	cromo
603.599	menta F-46	cromo



pata Símil roble

ref.	asiento	pata
503.592	pardo F-04	símil roble
503.593	gris F-14	símil roble
503.594	negro F-16	símil roble
503.595	verde F-37	símil roble
503.596	azulón F-38	símil roble
503.597	amarillo F-44	símil roble
503.598	coral F-36	símil roble
503.599	menta F-46	símil roble

pata Ruedas

ref.	asiento	pata
603.672	pardo F-04	Ruedas negro
603.673	gris F-14	Ruedas negro
603.674	negro F-16	Ruedas negro
603.675	verde F-37	Ruedas negro
603.676	azulón F-38	Ruedas negro
603.677	amarillo F-44	Ruedas negro
603.678	coral F-36	Ruedas negro
603.679	menta F-46	Ruedas negro

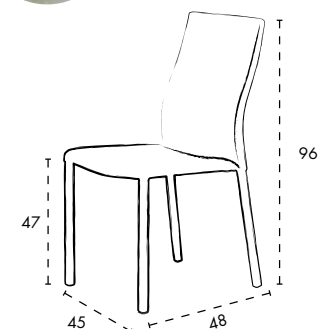



patas negro

REF.	ASIENTO	PATA
603.310	grey B-5	negro
603.311	ash B-12	negro
603.312	tabac B-8	negro
603.313	camel B-7	negro
603.314	turquesa B-10	negro
603.315	mostaza B-6	negro

patas blanco

REF.	ASIENTO	PATA
603.328	grey B-5	blanco
603.329	ash B-12	blanco
603.330	tabac B-8	blanco
603.331	camel B-7	blanco
603.332	turquesa B-10	blanco
603.333	mostaza B-6	blanco

patas piedra

REF.	ASIENTO	PATA
603.606	grey B-5	piedra
603.607	ash B-12	piedra
603.608	tabac B-8	piedra
603.609	camel B-7	piedra
603.610	turquesa B-10	piedra
603.611	mostaza B-6	piedra

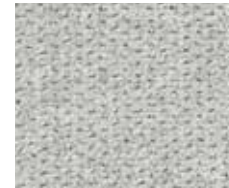

B-5 GREY



B-7 CAMEL



B-8 TABAC

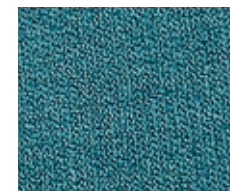

B-10 TURQUESA



B-12 ASH



B-6 MOSTAZA



pata Ruedas

REF.	ASIENTO	PATA
603.666	grey B-5	ruedas negro
603.667	ash B-12	ruedas negro
603.668	tabac B-8	ruedas negro
603.669	camel B-7	ruedas negro
603.670	turquesa B-10	ruedas negro
603.671	mostaza B-6	ruedas negro



patas gris

REF.	ASIENTO	PATA
603.626	grey B-5	gris
603.627	ash B-12	gris
603.628	tabac B-8	gris
603.629	camel B-7	gris
603.630	turquesa B-10	gris
603.631	mostaza B-6	gris

patas cromo brillo

REF.	ASIENTO	PATA
603.586	grey B-5	cromo
603.587	ash B-12	cromo
603.588	tabac B-8	cromo
603.589	camel B-7	cromo
603.590	turquesa B-10	cromo
603.591	mostaza B-6	cromo

patas símil roble

REF.	ASIENTO	PATA
503.586	grey B-5	símil roble
503.587	ash B-12	símil roble
503.588	tabac B-8	símil roble
503.589	camel B-7	símil roble
503.590	turquesa B-10	símil roble
503.591	mostaza B-6	símil roble

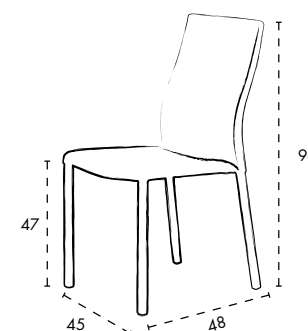



patas
negro

REF.	ASIENTO	PATA
603.640	M-1	negro
603.641	M-3	negro
603.642	M-4	negro
603.643	M-5	negro
603.644	M-6	negro

patas
blanco

REF.	ASIENTO	PATA
603.645	M-1	blanco
603.646	M-3	blanco
603.647	M-4	blanco
603.648	M-5	blanco
603.649	M-6	blanco

patas
piedra

REF.	ASIENTO	PATA
603.650	M-1	piedra
603.651	M-3	piedra
603.652	M-4	piedra
603.653	M-5	piedra
603.654	M-6	piedra

patas
gris

REF.	ASIENTO	PATA
603.655	M-1	gris
603.656	M-3	gris
603.657	M-4	gris
603.658	M-5	gris
603.659	M-6	gris

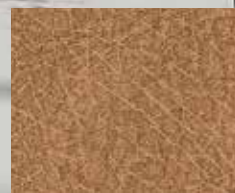
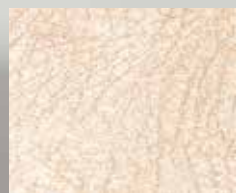

M1

M3

M4

M5

M6

patas
cromo brillo

REF.	ASIENTO	PATA
603.770	M-1	cromo
603.771	M-3	cromo
603.772	M-4	cromo
603.773	M-5	cromo
603.774	M-6	cromo

patas
símil roble

REF.	ASIENTO	PATA
503.770	M-1	símil roble
503.771	M-3	símil roble
503.772	M-4	símil roble
503.773	M-5	símil roble
503.774	M-6	símil roble

patas
ruedas

REF.	ASIENTO	PATA
603.680	M-1	ruedas negro
603.681	M-3	ruedas negro
603.682	M-4	ruedas negro
603.683	M-5	ruedas negro
603.684	M-6	ruedas negro

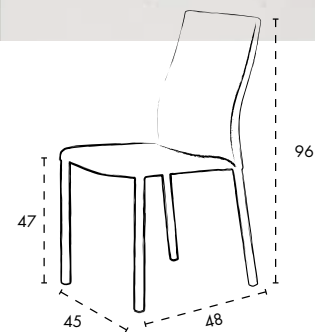



GRUPO **INTERMOBEL**

pata negro

REF.	ASIENTO	PATA
603.320	blanco A-3	negro
603.321	humo A-2	negro
603.322	roca A-4	negro
603.323	crema A-5	negro
603.324	ceniza A-12	negro
603.325	azul A-14	negro
603.326	tela cliente	negro

pata blanco

REF.	ASIENTO	PATA
603.334	blanco A-3	blanco
603.335	humo A-2	blanco
603.336	roca A-4	blanco
603.337	crema A-5	blanco
603.338	ceniza A-12	blanco
603.339	azul A-14	blanco
603.327	tela cliente	blanco

pata piedra

REF.	ASIENTO	PATA
603.600	blanco A-3	piedra
603.601	humo A-2	piedra
603.602	roca A-4	piedra
603.603	crema A-5	piedra
603.604	ceniza A-12	piedra
603.605	azul A-14	piedra
603.317	tela cliente	piedra

pata gris

REF.	ASIENTO	PATA
603.620	blanco A-3	gris
603.621	humo A-2	gris
603.622	roca A-4	gris
603.623	crema A-5	gris
603.624	ceniza A-12	gris
603.625	azul A-14	gris
603.318	tela cliente	gris



pata
cromo brillo

REF.	ASIENTO	PATA
603.580	blanco A-3	cromo
603.581	humo A-2	cromo
603.582	roca A-4	cromo
603.583	crema A-5	cromo
603.584	ceniza A-12	cromo
603.585	azul A-14	cromo
603.316	tela cliente	cromo

pata
símil roble

REF.	ASIENTO	PATA
503.580	blanco A-3	símil roble
503.581	humo A-2	símil roble
503.582	roca A-4	símil roble
503.583	crema A-5	símil roble
503.584	ceniza A-12	símil roble
503.585	azul A-14	símil roble
503.316	tela cliente	símil roble

pata
ruedas

REF.	ASIENTO	PATA
603.660	blanco A-3	ruedas negro
603.661	humo A-2	ruedas negro
603.662	roca A-4	ruedas negro
603.663	crema A-5	ruedas negro
603.664	ceniza A-12	ruedas negro
603.665	azul A-14	ruedas negro
603.319	tela cliente	ruedas negro

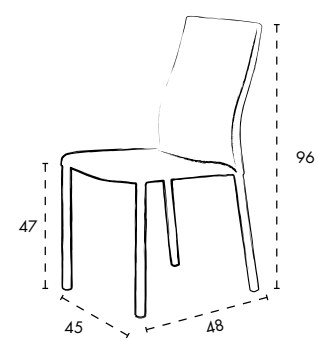

Tapizados

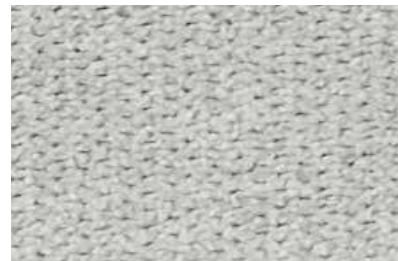

B5 Grey



B7 Camel



B8 Tabac

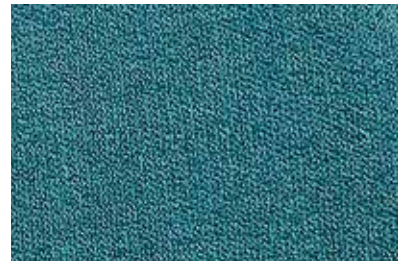

B10 Turquesa



B12 Ash



B6 Mostaza



Concha



INTERMOBEL



Silla CONCHA |

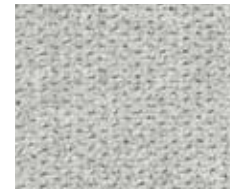

B-5 GREY



B-7 CAMEL



B-8 TABAC



B-10 TURQUESA



B-12 ASH



B-6 MOSTAZA



pata negro

REF.	ASIENTO	PATA
602.300	grey B-5	negro
602.301	ash B-12	negro
602.302	tabac B-8	negro
602.303	camel B-7	negro
602.304	turquesa B-10	negro
602.306	mostaza B-6	negro

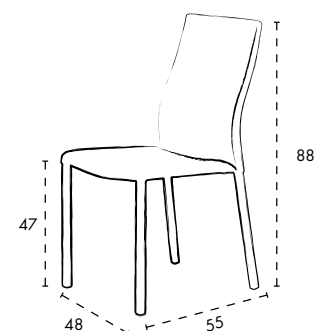

Tapizados

BELFAST



NEGRO F16



GRIS F14



PARDO F04



CORAL F36



AMARILLO F44



MENTA F46



VERDE F37



AZULÓN F38

MAGNUM



M1



M3



M4



M5

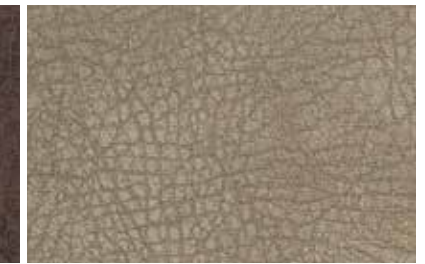

M6

Emy

INTERMOBEL





NEGRO F16



GRIS F14





PARDO F04



CORAL F36



AMARILLO F44



MENTA F46



VERDE F37

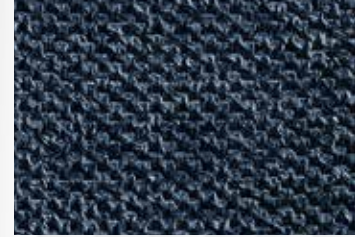

AZULÓN F38

muebles
INTERMOBEL



pata Negro

ref.	asiento	pata
501.580	pardo F-04	negro
501.581	gris F-14	negro
501.582	negro F-16	negro
501.583	verde F-37	negro
501.584	azulón F-38	negro
501.585	amarillo F-44	negro
501.586	coral F-36	negro
501.587	menta F-46	negro

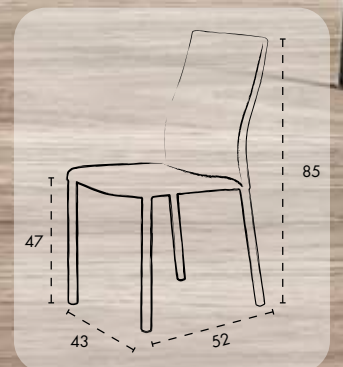



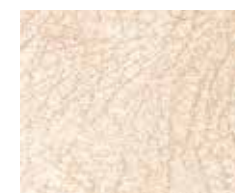

M1



M3



M4



M5



M6

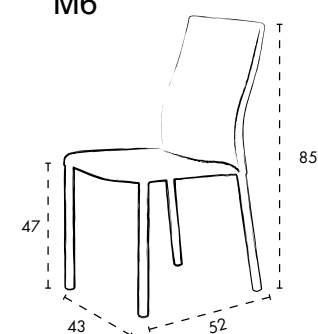

pata
negro

REF.	ASIENTO	color
501.570	M-1	negro
501.571	M-3	negro
501.572	M-4	negro
501.573	M-5	negro
501.574	M-6	negro
501.575	tela cliente	negro

Tapizados

BELFAST



NEGRO F16



GRIS F14



PARDO F04



CORAL F36



AMARILLO F44



MENTA F46



VERDE F37

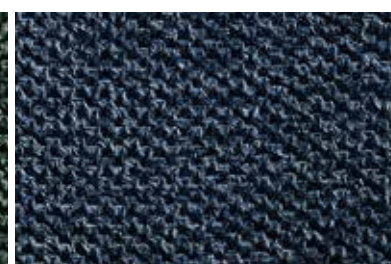

AZULÓN F38

TELA BRIDO

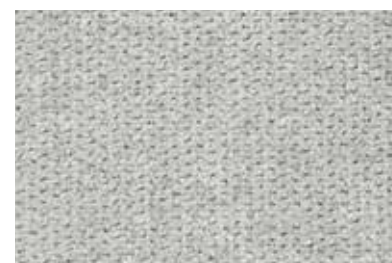

B5 Grey



B7 Camel



B8 Tabac

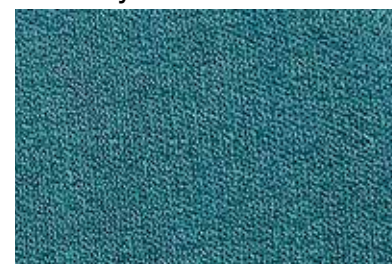

B10 Turquesa



B12 Ash



B6 Mostaza

MAGNUM



M1



M3



M4



M5



M6

AFRICA

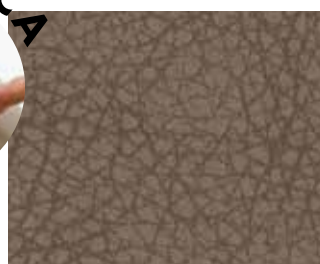

A2 Humo

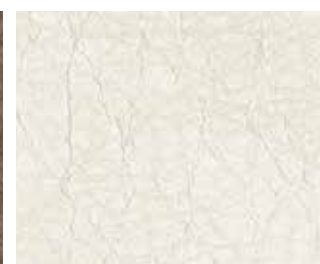

A3 Blanco

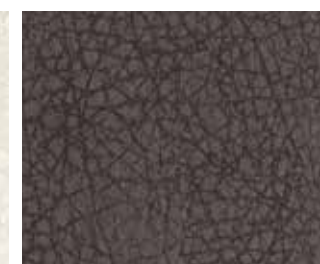

A4 Roca

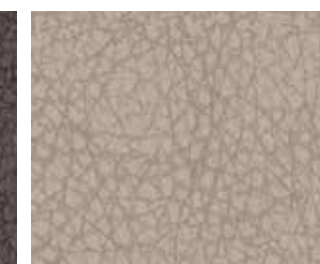

A5 Crema

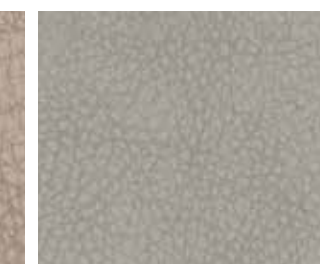

A12 Ceniza



A14 Azul

Mia

STUDIO
INTERMOBEL



NEGRO F16



GRIS F14





PARDO F04



CORAL F36



AMARILLO F44



MENTA F46



VERDE F37



AZULÓN F38



pata Negro

ref.	asiento	pata
501.880	pardo F-04	negro
501.881	gris F-14	negro
501.882	negro F-16	negro
501.883	verde F-37	negro
501.884	azulón F-38	negro
501.885	amarillo F-44	negro
501.886	coral F-36	negro
501.887	menta F-46	negro

pata Blanco

ref.	asiento	pata
501.870	pardo F-04	blanco
501.871	gris F-14	blanco
501.872	negro F-16	blanco
501.873	verde F-37	blanco
501.874	azulón F-38	blanco
501.875	amarillo F-44	blanco
501.876	coral F-36	blanco
501.877	menta F-46	blanco

pata Piedra

ref.	asiento	pata
501.890	pardo F-04	piedra
501.891	gris F-14	piedra
501.892	negro F-16	piedra
501.893	verde F-37	piedra
501.894	azulón F-38	piedra
501.895	amarillo F-44	piedra
501.896	coral F-36	piedra
501.897	menta F-46	piedra

pata Gris

ref.	asiento	pata
501.900	pardo F-04	gris
501.901	gris F-14	gris
501.902	negro F-16	gris
501.903	verde F-37	gris
501.904	azulón F-38	gris
501.905	amarillo F-44	gris
501.906	coral F-36	gris
501.907	menta F-46	gris

pata Cromo brillo

ref.	asiento	pata
501.860	pardo F-04	cromo
501.861	gris F-14	cromo
501.862	negro F-16	cromo
501.863	verde F-37	cromo
501.864	azulón F-38	cromo
501.865	amarillo F-44	cromo
501.866	coral F-36	cromo
501.867	menta F-46	cromo

GRUPO **muebles**
INTERMOBEL

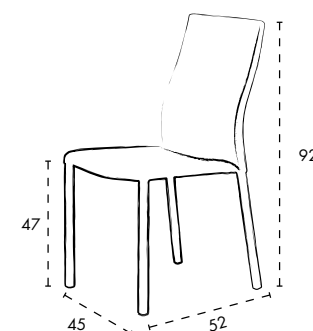



patas negro

REF.	ASIENTO	PATA
501.690	grey B-5	negro
501.691	ash B-12	negro
501.692	tabac B-8	negro
501.693	camel B-7	negro
501.694	turquesa B-10	negro
501.695	mostaza B-6	negro

patas blanco

REF.	ASIENTO	PATA
602.610	grey B-5	blanco
602.611	ash B-12	blanco
602.612	tabac B-8	blanco
602.613	camel B-7	blanco
501.689	turquesa B-10	blanco
602.650	mostaza B-6	blanco

patas piedra

REF.	ASIENTO	PATA
602.625	grey B-5	piedra
602.626	ash B-12	piedra
501.687	tabac B-8	piedra
501.688	camel B-7	piedra
602.627	turquesa B-10	piedra
602.651	mostaza B-6	piedra



B-5 GREY



B-7 CAMEL



B-8 TABAC

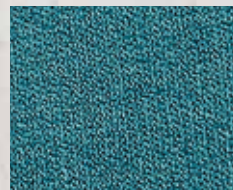

B-10 TURQUESA



B-12 ASH



B-6 MOSTAZA

GRUPPO MUEBLES
INTERMOBEL



Silla MIA |

patas
gris

REF.	ASIENTO	PATA
501.685	grey B-5	gris
501.686	ash B-12	gris
602.638	tabac B-8	gris
602.639	camel B-7	gris
602.640	turquesa B-10	gris
602.652	mostaza B-6	gris

patas
cromo brillo

REF.	ASIENTO	PATA
501.675	grey B-5	cromo
501.676	ash B-12	cromo
501.677	tabac B-8	cromo
501.678	camel B-7	cromo
501.679	turquesa B-10	cromo
602.653	mostaza B-6	cromo

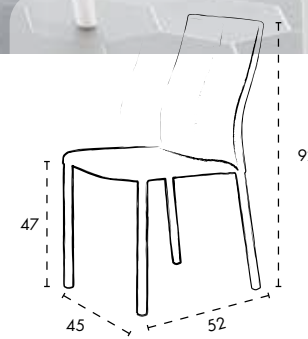

Mia MAGNUM



Silla MÍA |

GRUPO **INTERMOBEL**

patas negro

REF.	ASIENTO	PATA
501.821	M-1	negro
501.823	M-3	negro
501.824	M-4	negro
501.825	M-5	negro
501.826	M-6	negro

patas blanco

REF.	ASIENTO	PATA
602.659	M-1	blanco
602.660	M-3	blanco
602.661	M-4	blanco
602.662	M-5	blanco
602.663	M-6	blanco

patas piedra

REF.	ASIENTO	PATA
602.664	M-1	piedra
602.665	M-3	piedra
602.666	M-4	piedra
602.667	M-5	piedra
602.668	M-6	piedra

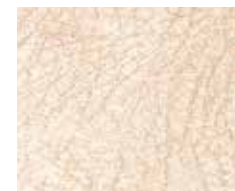

M1



M3



M4

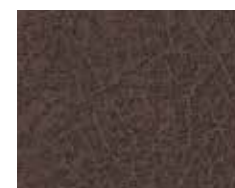

M5



M6



patas
gris

REF.	ASIENTO	PATA
602.669	M-1	gris
602.670	M-3	gris
602.671	M-4	gris
602.672	M-5	gris
602.673	M-6	gris

patas
cromo brillo

REF.	ASIENTO	PATA
602.654	M-1	cromo
602.655	M-3	cromo
602.656	M-4	cromo
602.657	M-5	cromo
602.658	M-6	cromo

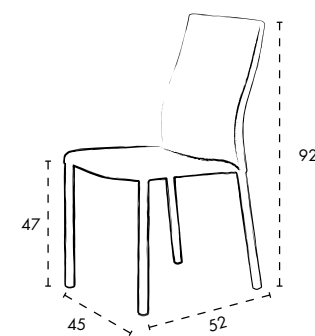

105



GRUPO **INTERMOBEL**

Silla MIA |

patas negro

REF.	ASIENTO	PATA
602.592	blanco A-3	negro
501.790	humo A-2	negro
501.791	roca A-4	negro
501.792	crema A-5	negro
501.793	ceniza A-12	negro
501.794	azul A-14	negro
501.795	tela cliente	negro

patas blanco

REF.	ASIENTO	PATA
602.591	blanco A-3	blanco
602.606	humo A-2	blanco
602.607	roca A-4	blanco
602.608	crema A-5	blanco
501.663	ceniza A-12	blanco
602.609	azul A-14	blanco
501.670	tela cliente	blanco

patas piedra

REF.	ASIENTO	PATA
602.593	blanco A-3	piedra
501.660	humo A-2	piedra
602.622	roca A-4	piedra
501.662	crema A-5	piedra
602.623	ceniza A-12	piedra
602.624	azul A-14	piedra
501.671	tela cliente	piedra



A2 Humo



A3 Blanco



A4 Roca



A5 Crema



A12 Ceniza



A14 Azul

muebles
INTERMOBEL

patas
gris

REF.	ASIENTO	PATA
602.594	blanco A-3	gris
602.635	humo A-2	gris
501.661	roca A-4	gris
602.636	crema A-5	gris
602.637	ceniza A-12	gris
501.664	azul A-14	gris
501.672	tela cliente	gris

patas
chromo brillo

REF.	ASIENTO	PATA
602.590	blanco A-3	chromo
501.640	humo A-2	chromo
501.641	roca A-4	chromo
501.642	crema A-5	chromo
501.643	ceniza A-12	chromo
501.644	azul A-14	chromo
501.649	tela cliente	chromo

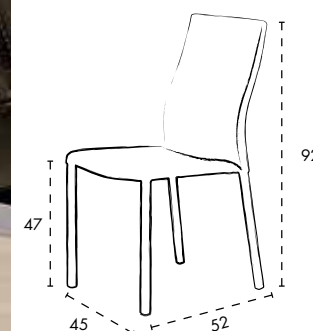

Tapizados

BELFAST



NEGRO F16



GRIS F14



PARDO F04



CORAL F36



AMARILLO F44



MENTA F46



VERDE F37

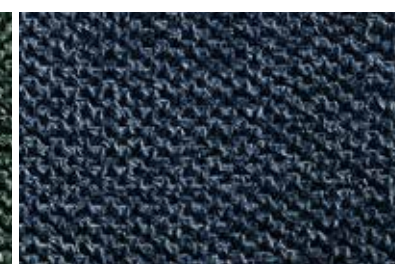

AZULÓN F38

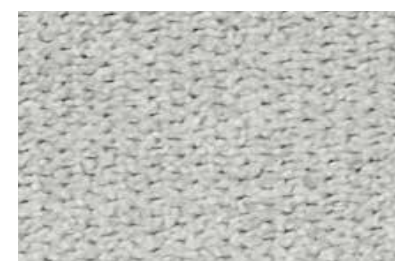

B5 Grey



B7 Camel



B8 Tabac

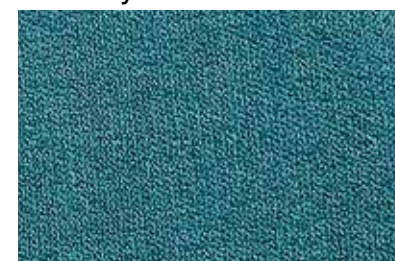

B10 Turquesa



B12 Ash

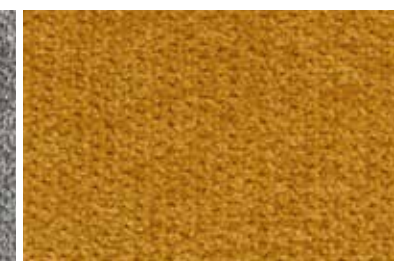

B6 Mostaza

ÁFRICA



A2 Humo

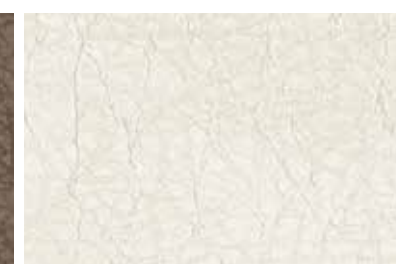

A3 Blanco

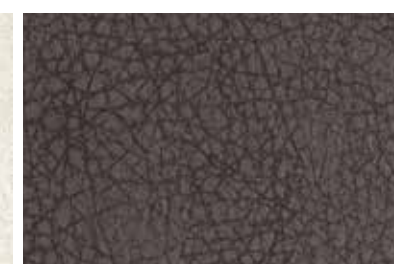

A4 Roca

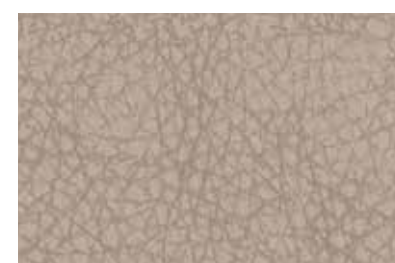

A5 Crema



A12 Ceniza



A14 Azul

Duna



INTERMOBEL



NEGRO F16



GRIS F14



pata Negro

ref.	asiento	pata
501.540	pardo F-04	negro
501.541	gris F-14	negro
501.542	negro F-16	negro
501.543	verde F-37	negro
501.544	azulón F-38	negro
501.545	amarillo F-44	negro
501.546	coral F-36	negro
501.547	menta F-46	negro



PARDO F04



CORAL F36



AMARILLO F44



MENTA F46



VERDE F37

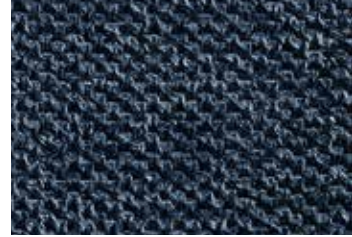

AZULÓN F38



pata Blanco

ref.	asiento	pata
501.550	pardo F-04	blanco
501.551	gris F-14	blanco
501.552	negro F-16	blanco
501.553	verde F-37	blanco
501.554	azulón F-38	blanco
501.555	amarillo F-44	blanco
501.556	coral F-36	blanco
501.557	menta F-46	blanco



Silla DUNA |

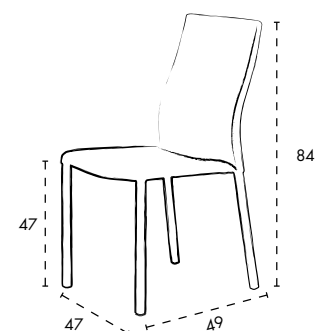

111



Duna BRIDO



B-5 GREY



B-7 CAMEL



B-8 TABAC



B-10 TURQUESA



B-12 ASH



B-6 MOSTAZA



muebles
GRUPO **INTERMOBEL**

patas negro

REF.	ASIENTO	PATA
501.850	grey B-5	negro
501.851	ash B-12	negro
501.852	tabac B-8	negro
501.853	camel B-7	negro
501.854	turquesa B-10	negro
501.855	mostaza B-6	negro

patas blanco

REF.	ASIENTO	PATA
602.432	grey B-5	blanco
602.433	ash B-12	blanco
602.434	tabac B-8	blanco
602.435	camel B-7	blanco
602.436	turquesa B-10	blanco
602.437	mostaza B-6	blanco

Duna ÁFRICA



GRUPO **INTERMOBEL**

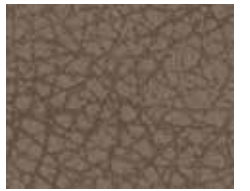

A2 Humo



A3 Blanco

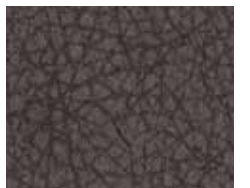

A4 Roca



A5 Crema



A12 Ceniza



A14 Azul

patas negro

REF.	ASIENTO	PATA
602.513	blanco A-3	negro
501.490	humo A-2	negro
501.491	roca A-4	negro
501.492	crema A-5	negro
501.493	ceniza A-12	negro
602.515	tela cliente	negro

patas blanco

REF.	ASIENTO	PATA
501.498	blanco A-3	blanco
602.501	humo A-2	blanco
602.502	roca A-4	blanco
602.503	crema A-5	blanco
602.504	ceniza A-12	blanco
602.514	tela cliente	blanco

Silla DUNA |

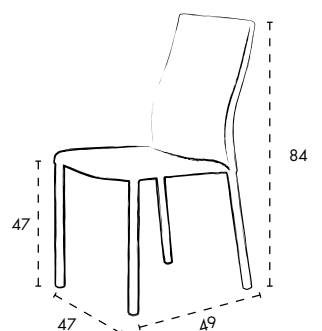

Tapizados

BELFAST



NEGRO F16



GRIS F14



PARDO F04



CORAL F36



AMARILLO F44



MENTA F46



VERDE F37

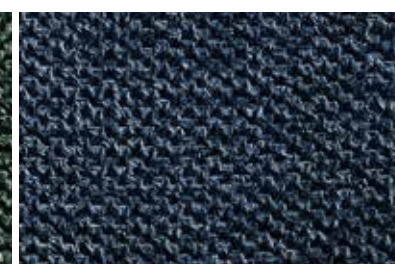

AZULÓN F38

TELA BRIDO

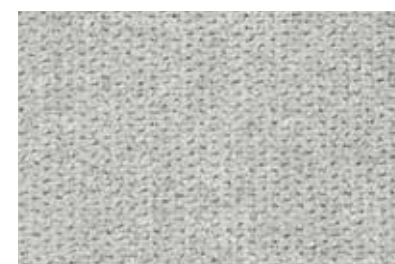

B5 Grey



B7 Camel



B8 Tabac

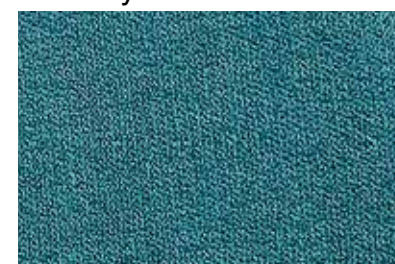

B10 Turquesa



B12 Ash



B6 Mostaza

ÁFRICA



M1



M3



M4



M5



M6

Celin



GRUPPO
INTERMOBEL

Celin

BELFAST

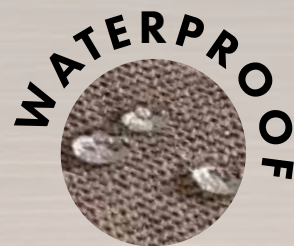

NEGRO F16



GRIS F14



INTERMOBEL

pata Negro

REF.	ASIENTO	PATA
603.370	pardo F-04	negro
603.371	gris F-14	negro
603.372	negro F-16	negro
603.373	verde F-37	negro
603.374	azulón F-38	negro
603.375	amarillo F-44	negro
603.376	coral F-36	negro
603.377	menta F-46	negro

pata Blanco

REF.	ASIENTO	PATA
603.360	pardo F-04	blanco
603.361	gris F-14	blanco
603.362	negro F-16	blanco
603.363	verde F-37	blanco
603.364	azulón F-38	blanco
603.365	amarillo F-44	blanco
603.366	coral F-36	blanco
603.367	menta F-46	blanco

pata Piedra

REF.	ASIENTO	PATA
603.380	pardo F-04	pedra
603.381	gris F-14	pedra
603.382	negro F-16	pedra
603.383	verde F-37	pedra
603.384	azulón F-38	pedra
603.385	amarillo F-44	pedra
603.386	coral F-36	pedra
603.387	menta F-46	pedra



PARDO F04



CORAL F36



AMARILLO F44



MENTA F46



VERDE F37

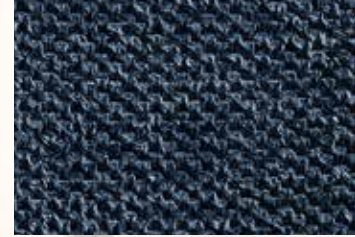

AZULÓN F38



pata Gris

REF.	ASIENTO	PATA
603.390	pardo F-04	gris
603.391	gris F-14	gris
603.392	negro F-16	gris
603.393	verde F-37	gris
603.394	azulón F-38	gris
603.395	amarillo F-44	gris
603.396	coral F-36	gris
603.397	menta F-46	gris

pata Cromo brillo

REF.	ASIENTO	PATA
603.400	pardo F-04	cromo
603.401	gris F-14	cromo
603.402	negro F-16	cromo
603.403	verde F-37	cromo
603.404	azulón F-38	cromo
603.405	amarillo F-44	cromo
603.406	coral F-36	cromo
603.407	menta F-46	cromo

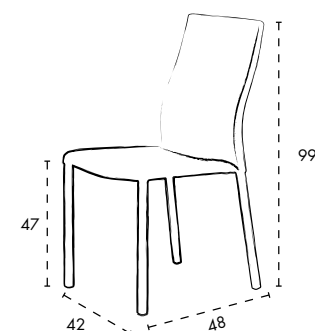



patas negro

REF.	ASIENTO	PATA
603.160	grey B-5	negro
603.161	ash B-12	negro
603.162	tabac B-8	negro
603.163	camel B-7	negro
603.164	turquesa B-10	negro
603.165	mostaza B-6	negro

patas blanco

REF.	ASIENTO	PATA
603.150	grey B-5	blanco
603.151	ash B-12	blanco
603.152	tabac B-8	blanco
603.153	camel B-7	blanco
603.154	turquesa B-10	blanco
603.155	mostaza B-6	blanco

patas piedra

REF.	ASIENTO	PATA
603.170	grey B-5	piedra
603.171	ash B-12	piedra
603.172	tabac B-8	piedra
603.173	camel B-7	piedra
603.174	turquesa B-10	piedra
603.175	mostaza B-6	piedra



B-5 GREY



B-7 CAMEL



B-8 TABAC



B-10 TURQUESA



B-12 ASH



B-6 MOSTAZA



patas
gris

REF.	ASIENTO	PATA
603.180	grey B-5	gris
603.181	ash B-12	gris
603.182	tabac B-8	gris
603.183	camel B-7	gris
603.184	turquesa B-10	gris
603.185	mostaza B-6	gris

patas
cromo brillo

REF.	ASIENTO	PATA
603.190	grey B-5	cromo
603.191	ash B-12	cromo
603.192	tabac B-8	cromo
603.193	camel B-7	cromo
603.194	turquesa B-10	cromo
603.195	mostaza B-6	cromo

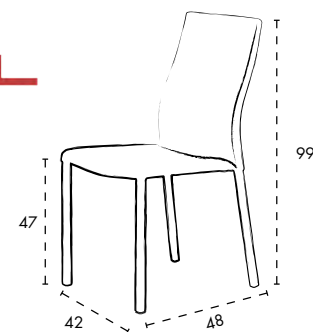



patas negro

REF.	ASIENTO	PATA
603.110	blanco A-3	negro
603.111	humo A-2	negro
603.112	roca A-4	negro
603.113	crema A-5	negro
603.114	ceniza A-12	negro
603.115	azul A-14	negro
603.116	tela cliente	negro

patas blanco

REF.	ASIENTO	PATA
603.100	blanco A-3	blanco
603.101	humo A-2	blanco
603.102	roca A-4	blanco
603.103	crema A-5	blanco
603.104	ceniza A-12	blanco
603.105	azul A-14	blanco
603.106	tela cliente	blanco

patas piedra

REF.	ASIENTO	PATA
603.120	blanco A-3	piedra
603.121	humo A-2	piedra
603.122	roca A-4	piedra
603.123	crema A-5	piedra
603.124	ceniza A-12	piedra
603.125	azul A-14	piedra
603.126	tela cliente	piedra



A2 HUMO



A3 BLANCO



A4 ROCA



A5 CREMA

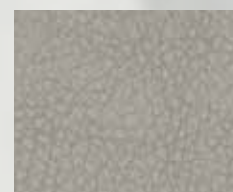

A12 CENIZA



A14 AZUL



patas gris

REF.	ASIENTO	PATA
603.130	blanco A-3	gris
603.131	humo A-2	gris
603.132	roca A-4	gris
603.133	crema A-5	gris
603.134	ceniza A-12	gris
603.135	azul A-14	gris
603.136	tela cliente	gris

patas cromo brillo

REF.	ASIENTO	PATA
603.140	blanco A-3	cromo
603.141	humo A-2	cromo
603.142	roca A-4	cromo
603.143	crema A-5	cromo
603.144	ceniza A-12	cromo
603.145	azul A-14	cromo
603.146	tela cliente	cromo

GRUPO **muebles**
INTERMOBEL

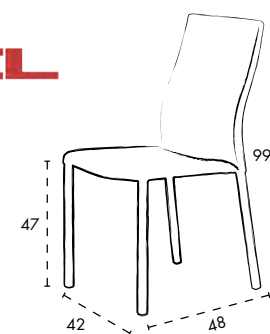

© MUEBLES SERES, S.A.

Reservados todos los derechos.

No se permite la reproducción, total o parcial, de ninguna parte de este catálogo y publicación en internet o sobre cualquier otro medio sin la autorización escrita de MUEBLES SERES.

Todos los productos, marcas comerciales y las fotografías reproducidas en este catálogo están sujetos a todas las leyes de propiedad intelectual existentes.

Los colores de este catálogo deben ser considerados orientativos.

© proyecto gráfico  <http://www.instagram.com/escrivamarketing/>

Impreso en España - 2022

All rights reserved.

Reproduction of any part of this catalogue and publication on the internet or on any other medium is not permitted without MUEBLES SERES written permission.

All products, trade-marks and photographs reproduced in this catalogue are subject to all existing intellectual property laws.

The colors of this catalogue should be considered merely illustrative.

© proyecto gráfico  <http://www.instagram.com/escrivamarketing/>

Printed in Spain - 2022

G R U P O
M U E B L E S
INTERMOBEL



Ctra. Nacional 340a, Km. 1050 - Apartado de correos 48
12500 Vinaròs (Castelló)

Tel. zona 1: 964 400 731

Aragón, Catalunya, Comunidad Valenciana,
Madrid, Murcia, Baleares y Canarias

Tel. zona 2: 964 400 001

Galicia, País Vasco, Asturias, Cantabria, Castilla Leon,
Castilla la Mancha, La Rioja, Navarra, Andalucía y Extremadura

Fax zona 1 y zona 2: 964 407 031

www.mueblesseres.com • comercial@mueblesseres.com

Modelos diseñados por Seres.

Modelos patentados.

© 2022 Muebles Seres